

DOT MATRIX PRINTER

SP317/347F

***USERS MANUAL
GUIDE D'UTILISATION
BEDIENUNGSANLEITUNG
MANUALE DI ISTRUZIONI***

stair 

**Federal Communications Commission
Radio Frequency Interference
Statement**

This equipment has been tested and found to comply with the limits for a Class A digital device, pursuant to Part 15 of the FCC Rules. These limits are designed to provide reasonable protection against harmful interference when the equipment is operated in a commercial environment. This equipment generates, uses, and can radiate radio frequency energy and, if not installed and used in accordance with the instruction manual, may cause harmful interference to radio communications. Operation of this equipment in a residential area is likely to cause harmful interference in which case the user will be required to correct the interference at his own expense.

For compliance with Federal Noise Interference Standard, this equipment requires a shielded cable.

This statement will be applied only for the printers marketed in U.S.A.

**Statement of
The Canadian Department of Communications
Radio Interference Regulations**

This digital apparatus does not exceed the Class A limits for radio noise emissions from digital apparatus set out in the Radio Interference Regulations of the Canadian Department of Communications.

Le présent appareil numérique n'émet pas de bruits radioélectriques dépassant les limites applicables aux appareils numériques de la classe A prescrites dans le Règlement sur le brouillage radioélectrique édicté par le ministère des Communications du Canada.

The above statement applies only to printers marketed in Canada.

**CE
Manufacturer's Declaration of Conformity
(EC Council Directive 89/336/EEC of 3 May 1989)**

This product has been designed and manufactured in accordance with the International Standards EN50081-1/01.92 and EN50082-1/01.92 following the provisions of the Electro Magnetic Compatibility Directive of the European Communities as of May 1989.

NOTICE

- *All rights reserved. Reproduction of any part of this manual in any form whatsoever, without STAR's express permission is forbidden.*
- *The contents of this manual are subject to change without notice.*
- *All efforts have been made to ensure the accuracy of the contents of this manual at the time of going to press. However, should any errors be detected, STAR would greatly appreciate being informed of them.*
- *The above notwithstanding, STAR can assume no responsibility for any errors in this manual.*

© Copyright 1996 Star Micronics Co., LTD.

TABLE OF CONTENTS

| | |
|---------------------------------------|----|
| 1. LOADING THE RIBBON CARTRIDGE | 2 |
| 1-1. SP317 | 2 |
| 1-2. SP347 | 3 |
| 2. LOADING THE PAPER | 5 |
| 2-1. SP317 | 5 |
| 2-2. SP347 | 7 |
| 2-3. Removing the Roll Paper | 10 |
| 3. CONTROL PANEL | 11 |
| APPENDIX | 49 |

1. LOADING THE RIBBON CARTRIDGE

1-1. SP317

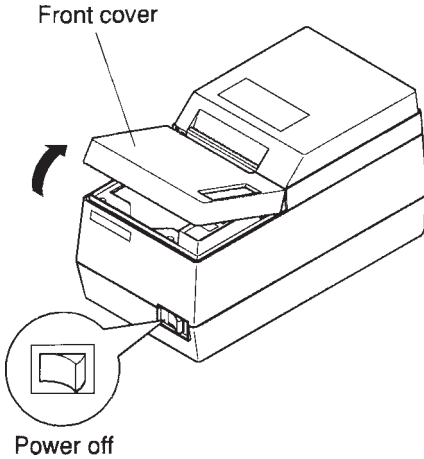

Fig. 1-1 Removing the front cover (SP317)

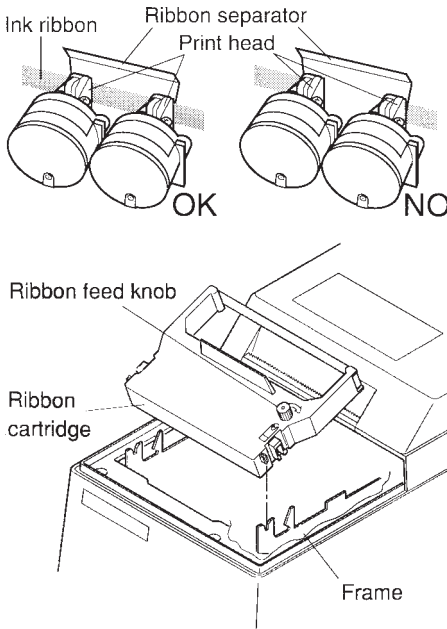
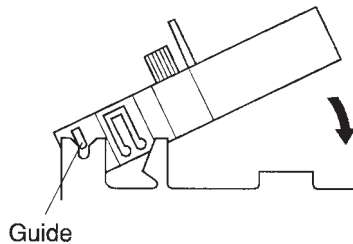

Fig. 1-2 Loading the ribbon cartridge (SP317)

- ① Turn the power switch on the printer to the off position.
- ② To remove the front cover lift it up approx. 3cm. and pull it forward.
NOTE: Do not touch the print head immediately after printing as it can be extremely hot.
- ③ To remove slack in the ribbon turn the ribbon feed knob of the ribbon cartridge in the direction of the arrow.
- ④ Align the ribbon cartridge guide with the notched part of the frame. Insert the ribbon cartridge from that position until you hear a locking sound. Insert the ink ribbon between the print head and the ribbon separator. Make sure that the ink ribbon is not protruding beyond the ribbon separator.
- ⑤ To remove slack in the ribbon turn the ribbon feed knob of the ribbon cartridge in the direction of the arrow.
- ⑥ To install the front cover reverse the removal steps.



1-2. SP347

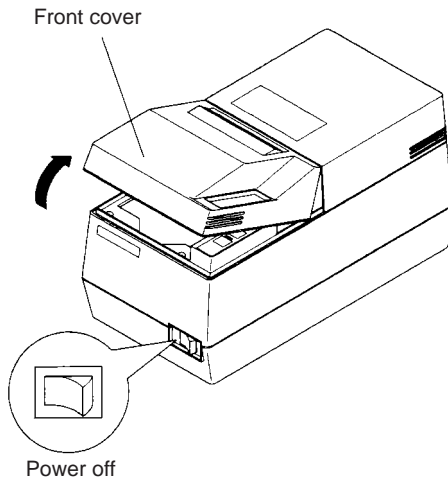

Fig. 1-3 Removing the front cover (SP347)

- ① Turn the power switch on the printer to the off position.
- ② To remove the front cover lift it up approx. 3cm. and pull it forward.

NOTE: Do not touch the print head immediately after printing as it can be extremely hot.

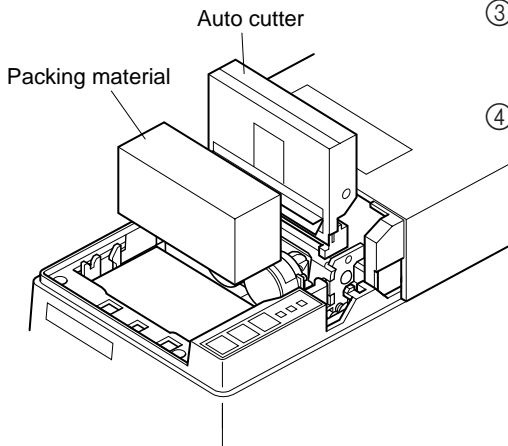
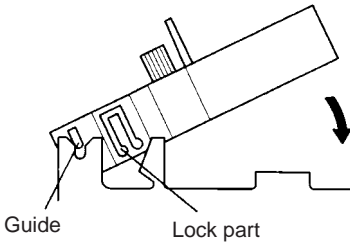
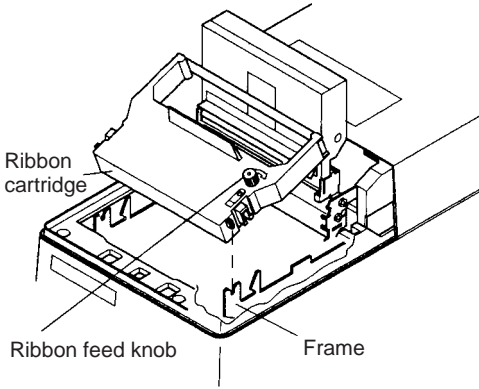

Fig. 1-4 Raise the auto cutter and remove the packing material (SP347)

- ③ Lift up the auto cutter and put it in a vertical position, as shown in Fig. 1-4.
- ④ Remove the packing material.



- ④ To remove slack in the ribbon turn the ribbon feed knob of the ribbon cartridge in the direction of the arrow.
- ⑤ Align the ribbon cartridge guide with the notched part of the frame. Insert the ribbon cartridge from that position until you hear a locking sound. Insert the ink ribbon between the print head and the ribbon separator. Make sure that the ink ribbon is not protruding beyond the ribbon separator.
- ⑥ To remove slack in the ribbon turn the ribbon feed knob of the ribbon cartridge in the direction of the arrow.

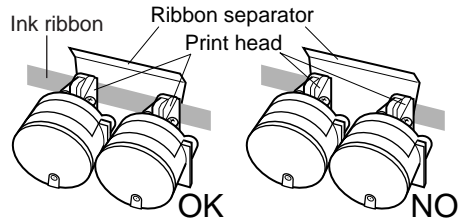

Fig. 1-5 Loading the ribbon cartridge (SP347)

- ⑦ Lower the auto cutter and install the front cover in the reverse order of its removal.

2. LOADING THE PAPER

2-1. SP317

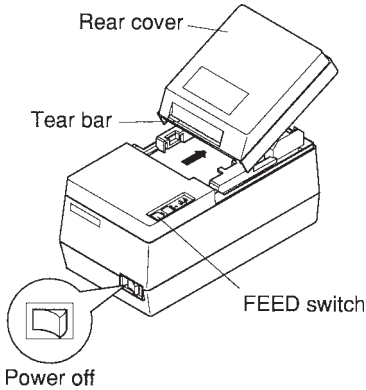

Fig. 2-1 Removing the rear cover (SP317)

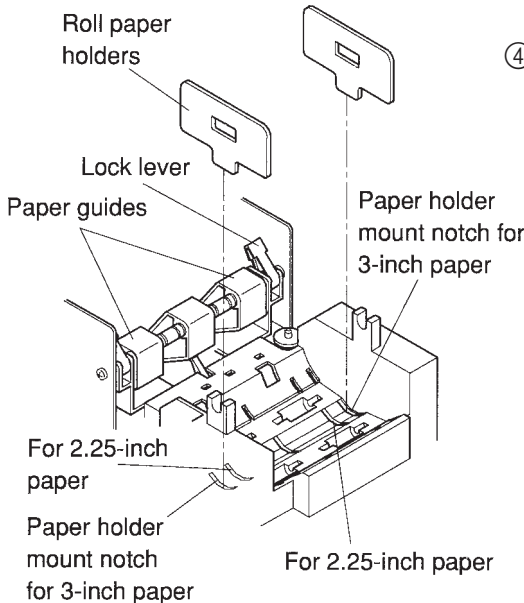

Fig. 2-2 Mounting the roll paper holders (SP317)

- ① Turn the power switch on the printer to the off position.
- ② Set DIP switch 2-4 to match the width of the paper that is being used. (Refer to Installation Manual for DIP switch settings.)

| DIP switches | ON | OFF |
|--------------|-------------|-------------|
| 2-4 | 3.25 inches | 2.25 inches |
| | 3.0 inches | |

(All the switches in the DIP switch array are factory preset to the “ON” position.)

- ③ To remove the rear cover lift it up approx. 3cm and push it backwards.
- ④ Dependant on the width of the paper (2.25 or 3 inches), align the roll paper holders at the specified position .

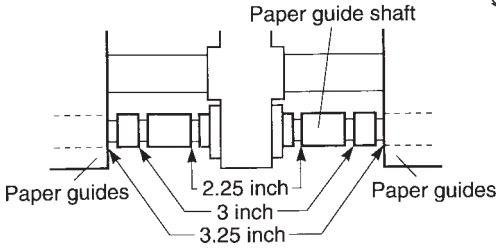

Fig. 2-3 Setting of the paper guide (SP317)

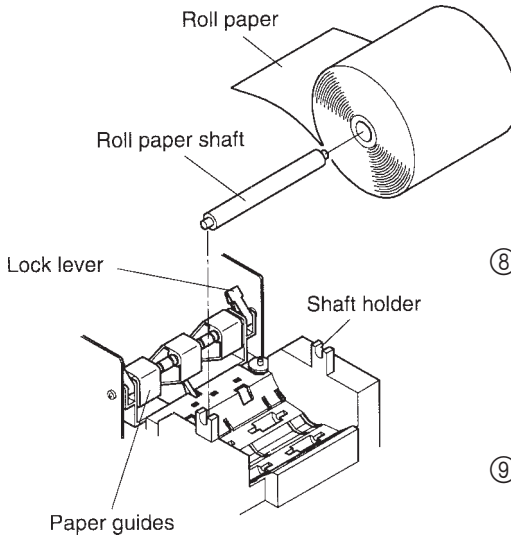

Fig. 2-4 Loading the paper (SP317)

- ⑤ Set the left and right paper guides. Leave a 0.5 mm gap between the paper guide and the edge of the paper and fix the lock lever.
- When you insert the stop ring that corresponds to the groove of the paper guide shaft shown in Fig. 2-3, that will be the position when you set the paper guide.

- ⑥ Turn the power switch on the printer to the on position.

- ⑦ Cut off the front edge of the roll paper in a straight line.

In case the front edge of the paper is fastened with a label, etc. remove the adhesive part of the label. If any adhesive remains on the paper, it will stick onto the roller of the printer, causing the paper to misfeed.

- ⑧ Hold the roll paper as shown in the illustration, then insert the top end of the paper beneath the paper guide as far as it will go and press the “FEED” switch on the control panel to feed the paper.

- ⑨ When the front edge of the paper feeds out of the printer, release the “FEED” switch. Next, insert the rollpaper into the roll paper shaft, and set the roll paper shaft on to the shaft holder.

- ⑩ Insert the top edge of the paper into the tear bar slot, then mount the rear cover by reversing the procedure for removing the rear cover in step ③ above.

NOTE: When the paper end mark appears on the paper, replace the roll paper before it runs out.

2-2. SP347

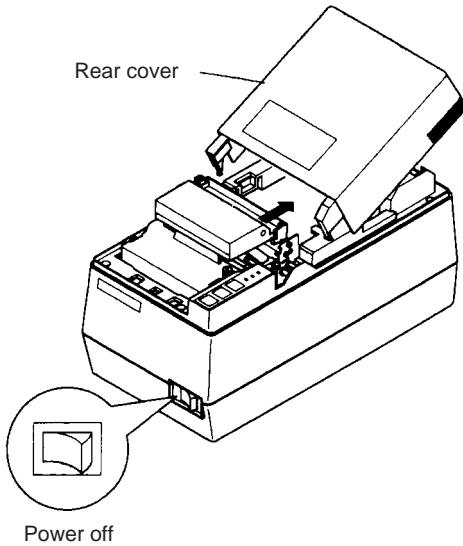

- ① Turn the power switch on the printer to the off position.
- ② To remove the front cover lift it up approx. 3cm. and pull it forward.
NOTE: Do not touch the print head immediately after printing as it can be extremely hot.
- ③ To remove the rear cover lift it up approx. 3cm and push it backwards.

Fig. 2-5 Removing the rear cover (SP347)

- ④ Adjust DIP switch 2-4, the roll paper holder and the adjust lever position according to the width and thickness of the roll paper that is being used.
 - Refer to Installation Manual in regard to the position of the DIP switch.
 - If you do not know the standard position of the adjust lever, lower the adjust lever as far as it will go (on the rear cover side), and then pull it two positions. That position is standard position A.

| Paper | | DIP switch 2-4 (Fig. 4-1) | Adjust lever position (Fig. 2-6) | Roll paper holder (Fig. 2-7) |
|-------------|------------------|------------------------------|-------------------------------------|---------------------------------|
| Paper width | Thickness | | | |
| 2.25 inches | 1 sheet of paper | OFF | A | Used (Inner groove) |
| | Printer paper | OFF | B | Used (Inner groove) |
| 3.0 inches | 1 sheet of paper | ON | A | Used (Outer groove) |
| | Printer paper | ON | B | Used (Outer groove) |
| 3.25 inches | 1 sheet of paper | ON | A | Not used |
| | Printer paper | ON | B | Not used |

- A: One Sheet of paper (standard position)
- B: Copy paper

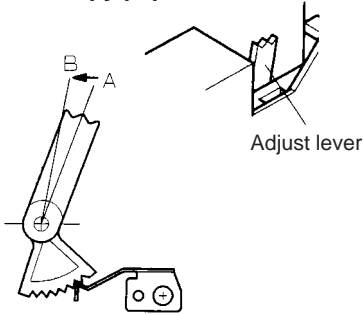

Fig. 2-6 Position of the adjust lever (SP347)

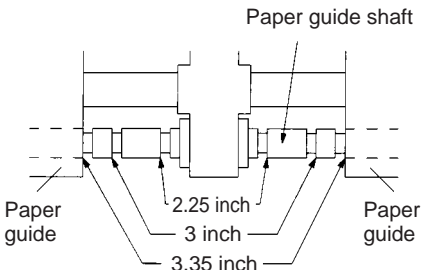

Fig. 2-8 Roll paper guide (SP347)

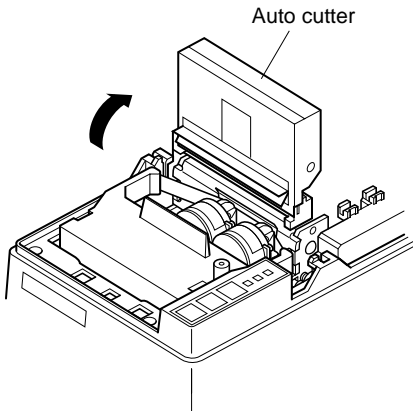

Fig. 2-9 Raise the auto cutter (SP347)

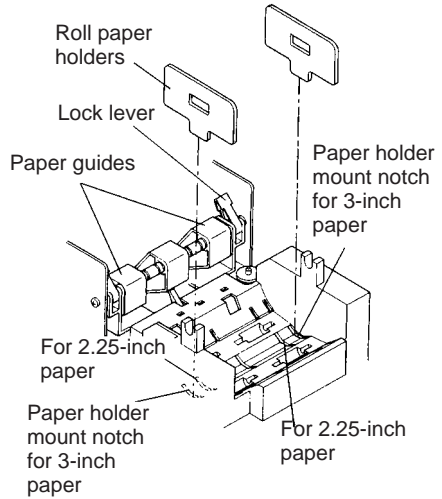

Fig. 2-7 Mounting the roll paper holders (SP347)

- ⑤ Set the left and right paper guides. Leave a 0.5 mm gap between the paper guide and the edge of the paper and fix the lock lever.
 - When you insert the stop ring that corresponds to the groove of the paper guide shaft shown in Fig. 2-8, that will be the position when you set the paper guide.
- ⑥ Lift up the auto cutter and put it in a vertical position, as shown in Fig. 2-9.

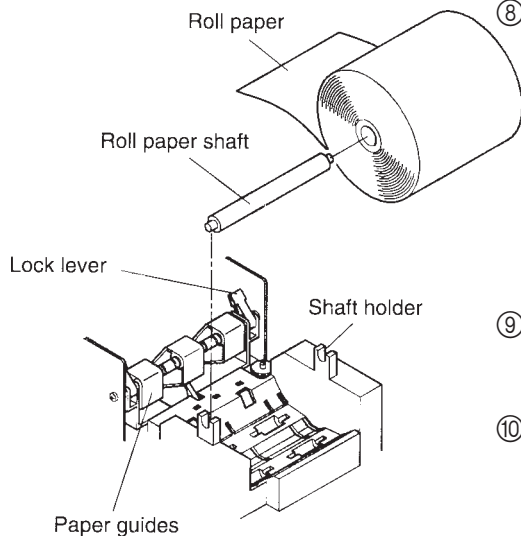

Fig. 2-10 Loading the paper (SP347)

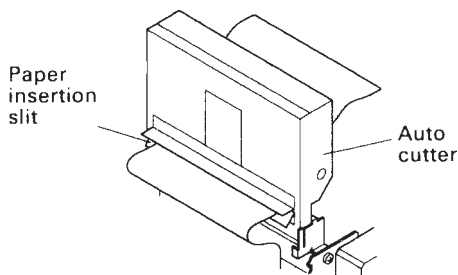
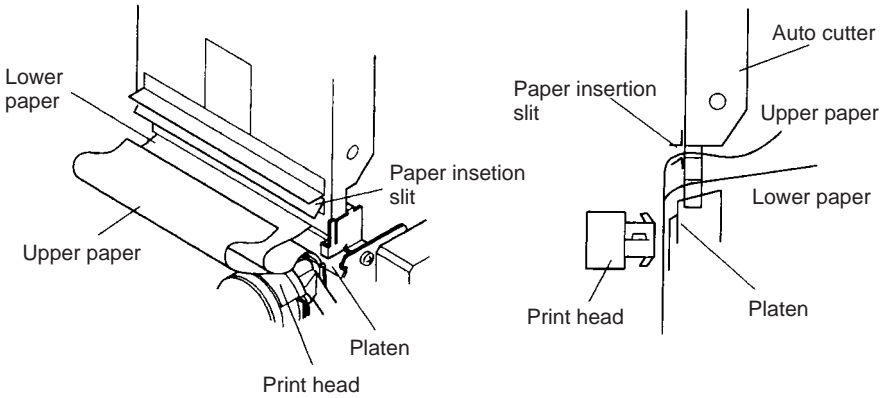
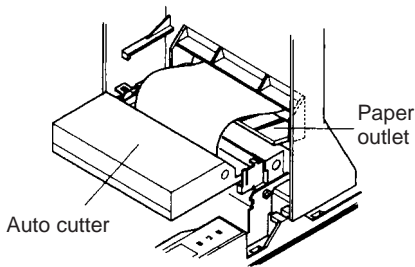

Fig. 2-11 Insertion of the paper into the auto cutter (SP347)

- ⑦ Turn the power switch on the printer to the on position.
- ⑧ Cut the tip of the roll paper in a straight line.
 - In case the front edge of the paper is fastened with a label, etc., remove the adhesive part of the label. If any adhesive remains on the paper, it will stick onto the roller of the printer, causing the paper to misfeed.
- ⑨ Observe the winding direction of the roll paper and insert the paper until it stops under the guide.
- ⑩ Press the FEED switch (paper feed) on the control panel
Release the switch when the roll paper has been fed out 10 cm from the paper outlet.
- ⑪ Insert the roll paper shaft into the paper roll and set it in the shaft holder.
- ⑫ Insert the tip of the roll paper in the auto cutter paper slit.
 - When using copying paper, insert only the original (the upper paper) into the slit of the auto cutter. Insert the paper which is to be copied (the lower paper) between the platen and the auto cutter. In this case, Rewinder PW300 (option) will be necessary in order to wind the paper that is copied. Refer to the user's manual of the rewinder for its setting method.



**Fig. 2-12 Insertion of the paper into the auto cutter
(When using copying paper) (SP347)**



**Fig. 2-13 Paper outlet of the front cover
(SP347)**

- ⑬ Pull on the edge of the paper to remove any slack and then lower the auto cutter.
- ⑭ Insert the paper through the front cover paper outlet and then replace the front cover by reversing the removal steps.
- ⑮ To install the rear cover reverse the removal steps.

2-3. Removing the Roll Paper

Remove the rear cover then cut off the paper near the rear of the paper guide. Then press the “FEED” switch to feed out the rest of the paper that is remaining in the unit.

When the paper runs out, a buzzer will sound four times per cycle for two cycles.

NOTE 1. Press the “FEED” switch to remove the rest of the paper that is in the printer. (If you remove the paper by hand, the paper could wrinkle or slip causing it to jam.)

NOTE 2. When the paper end mark appears on the paper, replace the roll paper before it runs out.

3. CONTROL PANEL

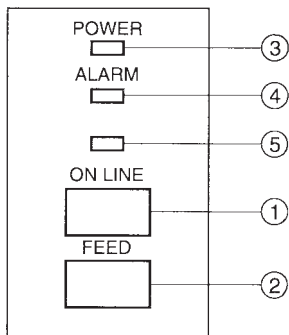

Fig. 3-1 Control panel

① “ON LINE” switch

Switches the printer between “ON LINE” and “OFF LINE”. Whenever the printer switches between “ON LINE” and “OFF LINE”, the buzzer gives one short beep (“ON LINE” and “OFF LINE” switching is possible only when the paper is loaded in the printer.)

② “FEED” switch

- When this switch is pressed and then released within 0.5 sec., the paper feeds one line.
- When this switch is depressed for more than 0.5 sec., the paper feeds continuously.

(The above paper feed operation is possible for both “ON LINE” and “OFF LINE” modes.)

③ “POWER” lamp (green LED)

- Lights when the power for the printer is on.

④ “ALARM” lamp (red LED)

- Lights when the paper is out.

If the paper is out, load a new roll then press the “ON LINE” switch.

- Flashes when the front cover is open or a mechanical error (motor lock etc.) occurs. The buzzer will give one short beep followed by a long beep.

Mount the front cover properly and press the “ON LINE” switch. If the buzzer still sounds and the “ALARM” lamp flashes, this signifies that a mechanical error has occurred. Locate the cause of the error and turn the power for the printer off and back on again to reset the printer.

(In case of a mechanical error, the data will not be cleared even if the power is turned off.)

⑤ “ON LINE” lamp (green LED)

LED lit: Printer is ON LINE

LED off: Printer is OFF LINE

LED flashes: Validation printing mode is set.

When all lamps ③ to ⑤ light simultaneously and the buzzer sounds continuously, a CPU error has occurred. In case of a CPU error, turn off the power then turn it on again. When turning off the power, the data will be cleared.

TABLE DES MATIÈRES

| | |
|--|----|
| 1. INSTALLATION D'UNE CARTOUCHE DE RUBAN | 14 |
| 1-1. SP317 | 14 |
| 1-2. SP347 | 15 |
| 2. CHARGEMENT DU PAPIER | 17 |
| 2-1. SP317 | 17 |
| 2-2. SP347 | 19 |
| 2-3. Enlèvement d'un rouleau de papier | 22 |
| 3. PANNEAU DE COMMANDE | 23 |
| APPENDICE | 49 |

L'appendice n'est pas traduit.

1. INSTALLATION D'UNE CARTOUCHE DE RUBAN

1-1. SP317

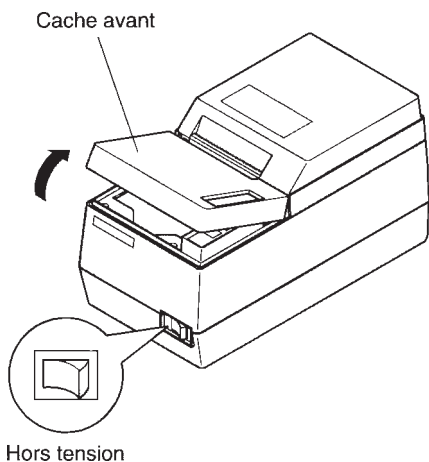

Fig. 1-1 Dépose du cache avant (SP317)

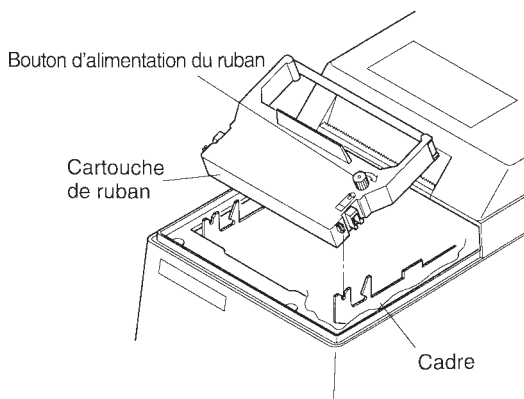
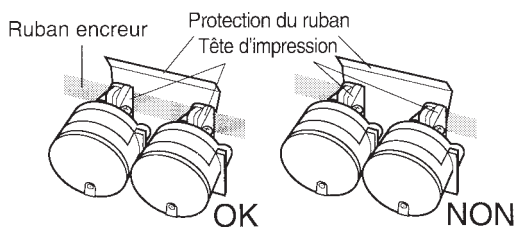
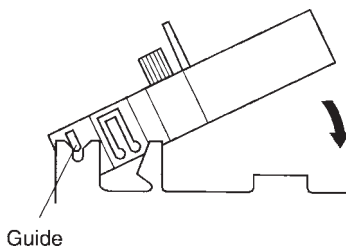

Fig. 1-2 Installation d'une cartouche de ruban (SP317)

- ① Mettez le commutateur d'alimentation de l'imprimante sur la position d'arrêt.
- ② Pour retirer le cache avant, soulevez-le d'environ 3 cm, puis tirez-le vers l'avant.
N.B. : Ne touchez pas la tête d'impression immédiatement après une impression ; en effet, celle-ci peut être très chaude.
- ③ Pour tendre le ruban, tournez le bouton d'alimentation du ruban de la cartouche dans la direction de la flèche.
- ④ Alignez le guide de la cartouche de ruban sur l'encoche du cadre, puis appuyez légèrement sur la cartouche de ruban afin qu'elle se mette en place. Vous entendrez un déclic une fois la cartouche bien en place. Insérez ensuite le ruban encreur entre la tête d'impression et la protection du ruban. Assurez-vous que le ruban encreur ne dépasse pas la protection du ruban.
- ⑤ Pour tendre le ruban, tournez le bouton d'alimentation du ruban de la cartouche dans la direction de la flèche.
- ⑥ Pour remonter le cache avant, effectuez les étapes de la dépose en sens inverse.



1-2. SP347

Cache avant

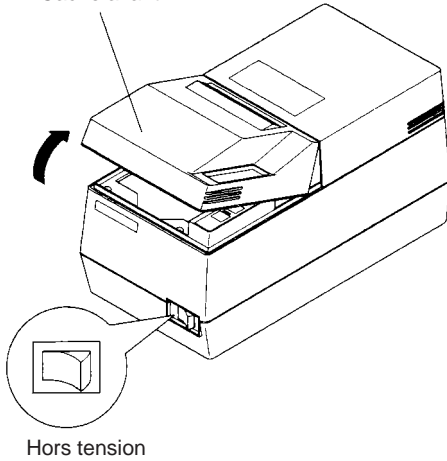

- ① Mettez le commutateur d'alimentation de l'imprimante sur la position d'arrêt.
- ② Pour retirer le cache avant, soulevez-le d'environ 3 cm, puis tirez-le vers l'avant.

N.B. : Ne touchez pas la tête d'impression immédiatement après une impression ; en effet, celle-ci peut être très chaude.

Fig. 1-3 Dépose du cache avant (SP347)

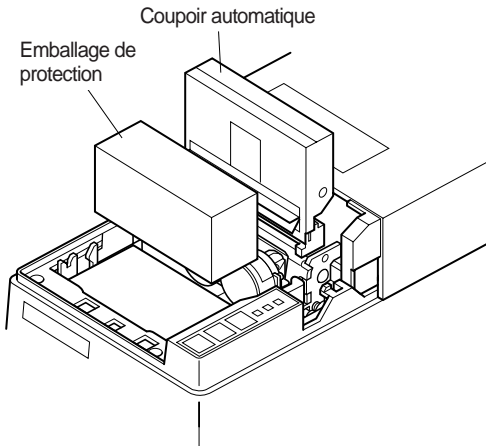

- ③ Relevez le coupoir automatique et placez-le à la verticale, comme illustré à la figure 1-4.
- ④ Retirez l'emballage de protection.

Fig. 1-4 Relèvement du coupoir automatique et enlèvement de l'emballage de protection (SP347)

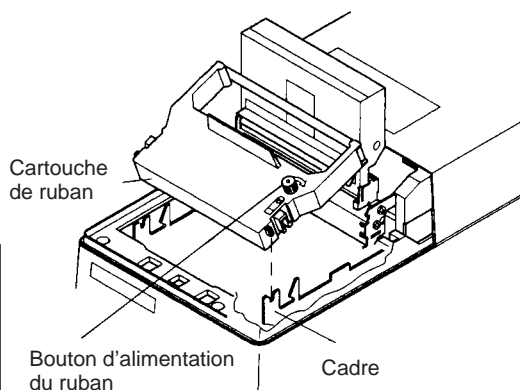

- ④ Pour tendre le ruban, tournez le bouton d'alimentation du ruban de la cartouche dans la direction de la flèche.
- ⑤ Alignez le guide de la cartouche de ruban sur l'encoche du cadre, puis appuyez légèrement sur la cartouche de ruban afin qu'elle se mette en place. Vous entendrez un déclic une fois la cartouche bien en place. Insérez ensuite le ruban encreur entre la tête d'impression et la protection du ruban. Assurez-vous que le ruban encreur ne dépasse pas la protection du ruban.
- ⑥ Pour tendre le ruban, tournez le bouton d'alimentation du ruban de la cartouche dans la direction de la flèche.

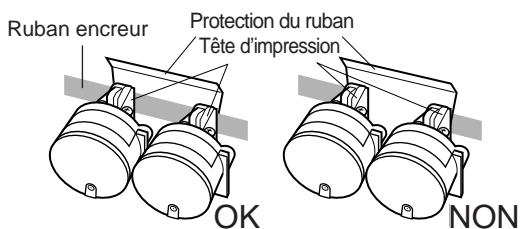
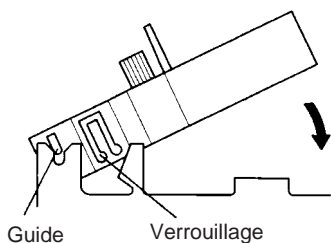

Fig. 1-5 Installation d'une cartouche de ruban (SP347)

- ⑦ Rabaissez le coupeur automatique et remplacez le cache avant en inversant les étapes de sa dépose.

2. CHARGEMENT DU PAPIER

2-1. SP317

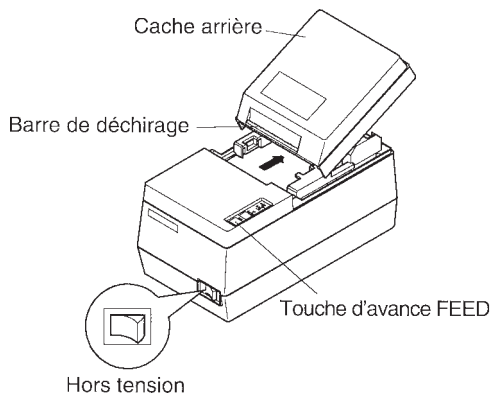

Fig. 2-1 Dépose du cache arrière (SP317)

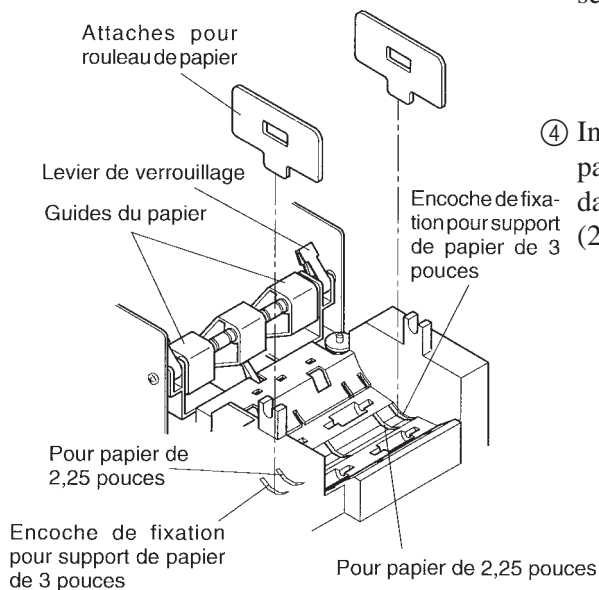

Fig. 2-2 Montage des attaches pour rouleau de papier (SP317)

- ① Mettez le commutateur d'alimentation de l'imprimante sur la position d'arrêt.
- ② Réglez l'interrupteur DIP 2-4 en fonction de la largeur du papier utilisé. (Se référer au Manuel d'installation pour les réglages des microrupteurs).

| Interrupteurs DIP | ON | OFF |
|----------------------|-------------|-------------|
| 2-4 | 3,25 pouces | 2,25 pouces |
| | 3,0 pouces | |

(Chacun des interrupteurs DIP sont pré-réglés sur la position "OUI".)

- ③ Pour retirer le cache arrière, relevez-le d'environ 3 cm, puis repoussez-le vers l'arrière.

- ④ Insérez les attaches de rouleau de papier dans les encoches correspondant à la largeur du papier utilisé (2,25 ou 3 pouces).

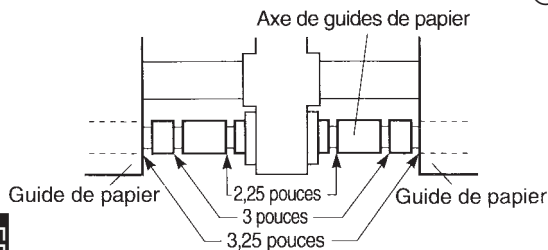

Fig. 2-3 Positionnement des guides de papier (SP317)

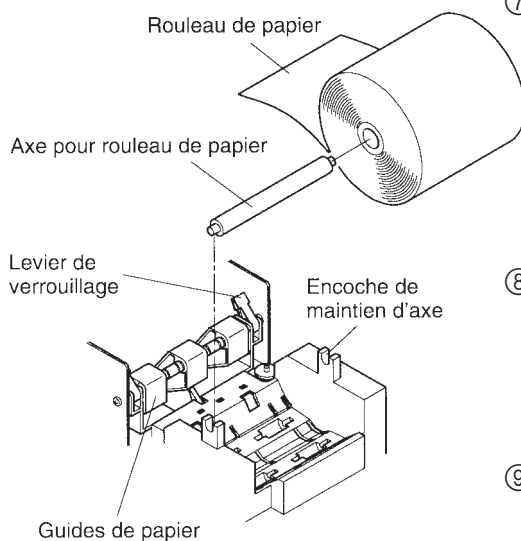
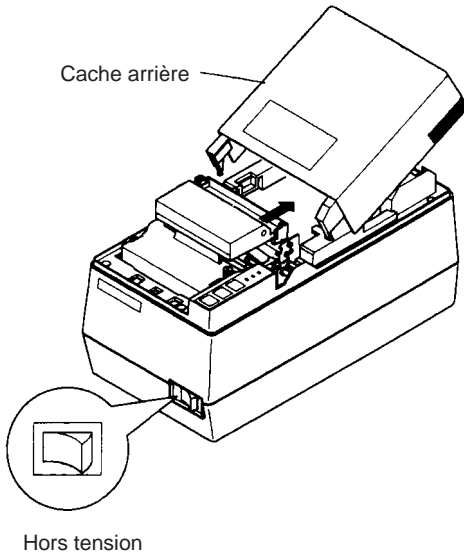

Fig. 2-4 Chargement du rouleau de papier (SP317)

- ⑤ Réglez la position des guides de papier gauche et droit. Veillez à laisser un espace de 0,5 mm entre l'extrémité du guide et du papier, puis bloquez le levier de verrouillage.
 - Pour régler la position des guides de papier, placez les anneaux d'arrêt dans les espaces sur l'axe des guides de papier qui correspondent à la largeur du papier à charger (voyez la figure 2-3).
- ⑥ Mettez le commutateur d'alimentation de l'imprimante sur la position de marche.
- ⑦ Coupez l'extrémité du papier en veillant à couper droit. Si l'extrémité du papier est fixée à l'aide d'un adhésif, il convient de l'éliminer. En effet, toute trace de matière adhésive sur le papier que vous insérez dans l'imprimante risque d'adhérer au rouleau d'impression et d'empêcher l'alimentation correcte du papier.
- ⑧ Placez le rouleau de papier comme illustré, puis insérez l'extrémité du papier aussi loin que possible sous le guide de papier et enfoncez ensuite la touche d'avance FEED du panneau de commande afin de faire avancer le papier.
- ⑨ Une fois que le papier ressort par la fente de sortie de l'imprimante, relâchez la touche d'avance FEED. Insérez ensuite l'axe pour rouleau de papier dans le rouleau de papier, puis mettez l'axe en place en le fixant dans les encoches de maintien.
- ⑩ Insérez l'extrémité du papier dans la fente de la barre de déchirage, puis remettez le cache arrière en place en inversant l'ordre de la dépose décrit au point 3 ci-avant.

N.B. : N'attendez pas que le rouleau soit épuisé avant de remplacer le rouleau de papier ; remplacez-le dès que la marque de fin de rouleau est apparente.

2-2. SP347



- ① Mettez le commutateur d'alimentation de l'imprimante sur la position d'arrêt.
- ② Pour retirer le cache avant, soulevez-le d'environ 3 cm, puis tirez-le vers l'avant.
N.B. : Ne touchez pas la tête d'impression immédiatement après une impression ; en effet, celle-ci peut être très chaude.
- ③ Pour retirer le cache arrière, relevez-le d'environ 3 cm, puis repoussez-le vers l'arrière.

Fig. 2-5 Dépose du cache arrière (SP347)

- ④ Réglez l'interrupteur DIP 2-4, les attaches pour rouleau de papier et le levier d'ajustement en fonction de la largeur et de l'épaisseur du rouleau de papier utilisé.
 - Les réglages des interrupteurs DIP sont expliqués dans le Guide d'installation.
 - Pour trouver la position standard A du levier d'ajustement, abaissez celui-ci le plus possible (côté cache arrière), puis relevez-le de deux crans.

| Papier | | Interrupteur DIP 2-4 (Fig. 4-1) | Position du levier d'ajustement (Fig. 2-6) | Attaches pour rouleau de papier (Fig. 2-7) |
|-------------------|---------------------|------------------------------------|---|---|
| Largeur du papier | Épaisseur | | | |
| 2,25 pouces | 1 feuille de papier | OFF | A | Utilisés (encoches intérieures) |
| | Papier d'imprimante | OFF | B | Utilisés (encoches intérieures) |
| 3,0 pouces | 1 feuille de papier | ON | A | Utilisés (encoches extérieures) |
| | Papier d'imprimante | ON | B | Utilisés (encoches extérieures) |
| 3,25 pouces | 1 feuille de papier | ON | A | Pas utilisés |
| | Papier d'imprimante | ON | B | Pas utilisés |

**A: Une feuille de papier
(position standard)
B: Papier de copie**

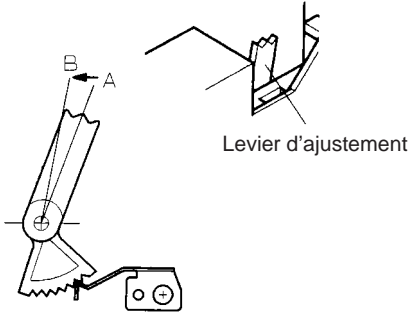

Fig. 2-6 Positionnement du levier d'ajustement (SP347)

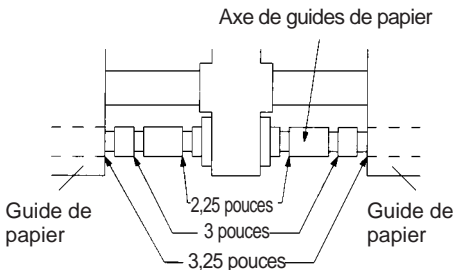

Fig. 2-8 Guide de rouleau de papier (SP347)

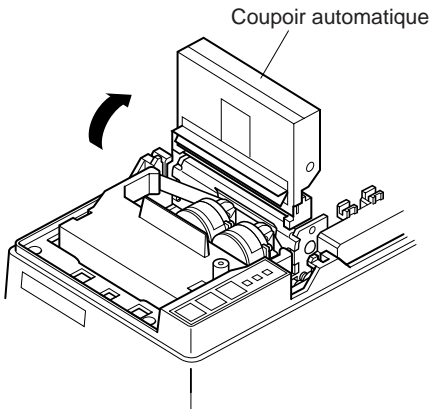

Fig. 2-9 Relèvement du coupoir automatique (SP347)

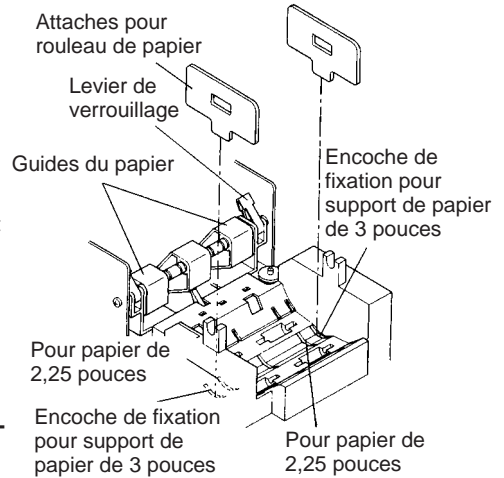

Fig. 2-7 Fixation des attaches pour rouleau de papier (SP347)

- ⑤ Réglez la position des guides de papier gauche et droit. Veillez à laisser un espace de 0,5 mm entre l'extrémité du guide et du papier, puis bloquez le levier de verrouillage.

- Pour régler la position des guides de papier, placez les anneaux d'arrêt dans les espaces sur l'axe des guides de papier qui correspondent à la largeur du papier à charger (voyez la figure 2-8).

- ⑥ Relevez le coupoir automatique et placez-le à la verticale, comme illustré à la figure 2-9.

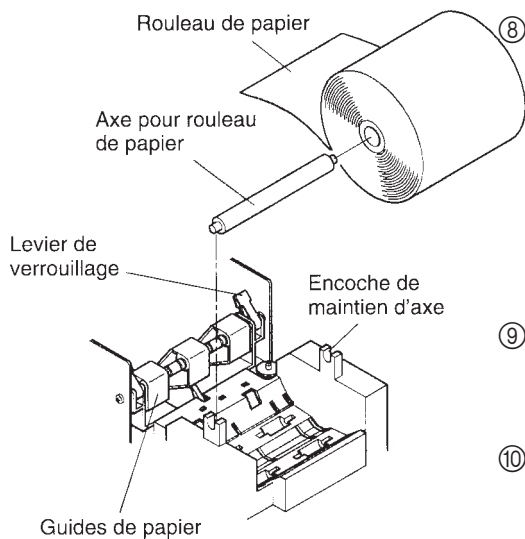

Fig. 2-10 Chargement du papier (SP347)

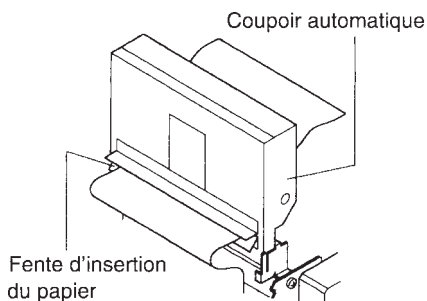
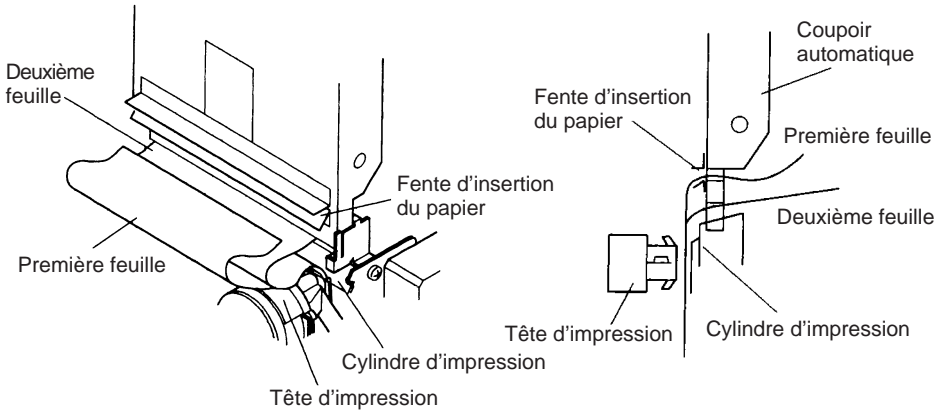
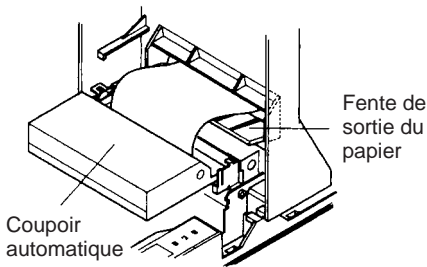

Fig. 2-11 Insertion du papier dans le coupoir automatique (SP347)

- ⑦ Mettez le commutateur d'alimentation de l'imprimante sur la position de marche.
- ⑧ Coupez l'extrémité du papier en veillant à couper droit.
 - Si l'extrémité du papier est fixée à l'aide d'un adhésif, il convient de l'éliminer. En effet, toute trace de matière adhésive sur le papier que vous insérez dans l'imprimante risque d'adhérer au rouleau et d'empêcher l'alimentation correcte du papier.
- ⑨ Placez le rouleau de papier comme illustré, puis insérez l'extrémité du papier aussi loin que possible sous le guide de papier.
- ⑩ Enfoncez ensuite la touche d'avance FEED du panneau de commande. Faire avancer le papier, de sorte qu'il ressorte de 10 cm par la fente de sortie de l'imprimante, puis relâchez la touche d'avance.
- ⑪ Insérez ensuite l'axe pour rouleau de papier dans le rouleau de papier, puis mettez l'axe en place en le fixant dans les encoches de maintien.
- ⑫ Insérez l'extrémité du papier dans la fente de la barre de déchirage.
 - Quand vous employez du papier de copie, insérez uniquement l'original (la première feuille de papier) dans la fente du coupoir automatique. Insérez le papier de copie (la deuxième feuille de papier) entre le cylindre et le coupoir automatique. Il est nécessaire d'installer une rebobineuse PW300 (vendue en option) afin de pouvoir rebobiner le papier de copie. Consultez le guide de l'utilisateur de la rebobineuse pour apprendre comment faire rebobiner le papier de copie.



**Fig. 2-12 Insertion du papier dans le coupair automatique
(avec papier de copie) (SP347)**



**Fig. 2-13 Fente de sortie du cache avant
(SP347)**

- ⑬ Tirez sur l'extrémité du papier afin de tendre le papier, puis rabaisser le coupair automatique.
- ⑭ Insérez le papier par la fente de papier du cache avant, puis remettez le cache avant en place en inversant l'ordre de sa dépose.
- ⑮ Remplacez le cache arrière en inversant l'ordre de sa dépose.

2-3. Enlèvement d'un rouleau de papier

Retirer le cache arrière, puis coupez le papier juste derrière le guide de papier. Enfoncez la touche d'avance FEED afin de faire sortir le reste du papier qui se trouve toujours dans l'imprimante.

Quand tout le papier est sorti, deux cycles de quatre bips sonores retentissent.

N.B. 1 : Enfoncez la touche d'avance FEED pour éliminer le reste du papier qui se trouve dans l'imprimante.

(Si vous retirez le papier à la main, celui-ci risque de se chiffonner ou de se mettre de travers et de causer un bourrage.)

N.B. 2 : N'attendez pas que le rouleau soit épuisé avant de remplacer le rouleau de papier ; remplacez-le dès que la marque de fin de rouleau est apparente.

3. PANNEAU DE COMMANDE

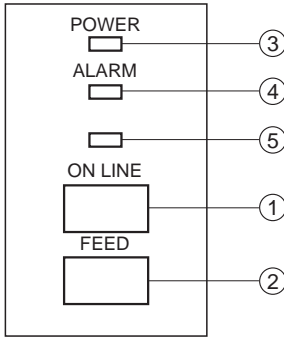

Fig. 3-1 Panneau de commande

① Touche “en ligne” ON LINE
Cette touche permet de commuter entre les états “en ligne” et “hors ligne”. Un bip sonore court retentit à chaque fois que l’imprimante passe d’un état à l’autre. Vous ne pouvez modifier l’état que si du papier est chargé dans l’imprimante.

② Touche d’avance FEED

- Si vous appuyez sur la touche, puis la relâchez dans la demi-seconde, le papier avance d’une ligne.
- Si vous appuyez sur la touche pendant plus d’une demi-seconde, le papier avance de façon continue. (Cela est valable à la fois pour le mode “en ligne” et le mode “hors ligne”).

- ③ Voyant de marche POWER (DEL verte)
- Ce voyant s’allume quand l’imprimante est en état de marche.
- ④ Voyant d’alerte ALARM (DEL rouge)
- S’allume quand le papier est épuisé. Quand le papier est épuisé, charger un nouveau rouleau, puis appuyez sur la touche ON LINE.
 - Ce voyant clignote quand le cache avant est ouvert ou une erreur mécanique (blocage de moteur, etc.) est détectée. Un bip sonore court retentit, suivi d’un long bip. Remplacez correctement le cache avant, puis appuyez sur la touche ON LINE. Si les bips sonores retentissent toujours et si le voyant ALARM clignote toujours, cela signifie qu’une erreur mécanique s’est produite. Localisez la cause de l’erreur et mettez l’imprimante hors tension pour réinitialiser celle-ci. (En cas d’erreur mécanique, les données ne sont pas effacées quand vous mettez l’imprimante hors tension.)
- ⑤ Voyant “en ligne” ON LINE (DEL verte)
- DEL allumée : l’imprimante est “en ligne”
DEL éteinte : l’imprimante est “hors ligne”
DEL clignote : l’imprimante est en mode d’impression “validation”
- Quand tous les voyants ③ à ⑤ s’allument simultanément et que des bips sonores retentissent de façon répétée signifie qu’une erreur s’est produite au niveau du processeur central. Dans ce cas, mettez l’appareil hors tension. Les données sont effacées à la mise hors tension de l’appareil.

INHALTSVERZEICHNIS

| | |
|--|----|
| 1. EINLEGEN DER FARBBANDKASSETTE | 26 |
| 1-1. SP317 | 26 |
| 1-2. SP347 | 27 |
| 2. EINLEGEN DES PAPIERS | 29 |
| 2-1. SP317 | 29 |
| 2-2. SP347 | 31 |
| 2-3. Entfernen des Rollenpapiers | 34 |
| 3. BEDIENFELD | 35 |
| ANHANG | 49 |

Der Anhang erscheint nur im englischen Teil dieser Bedienungsanleitung

1. EINLEGEN DER FARBBANDKASSETTE

1-1. SP317



Abb. 1-1 Frontabdeckung abnehmen (SP317)



Abb. 1-2 Einlegen der Farbbandkassette (SP317)

- ① Den Netzschalter am Drucker in Aus-Stellung stellen.
- ② Zum Abnehmen der Frontabdeckung diese ca. 3 cm anheben, und nach vorne ziehen.

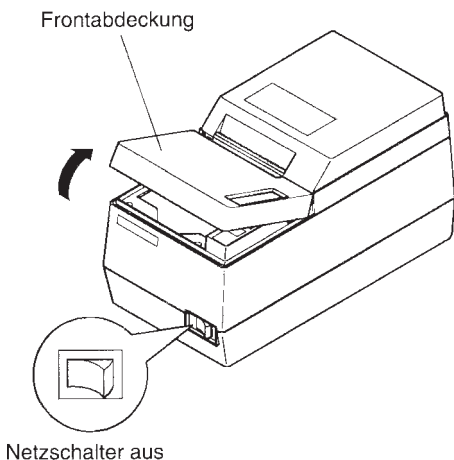
HINWEIS: Nicht den Druckkopf sofort nach dem Drucken berühren, da er sehr heiß sein kann.

- ③ Um Schlaufen im Farbband aufzuwickeln, den Farbbandzuführknopf der Farbbandkassette in Pfeilrichtung drehen.
- ④ Die Farbbandkassettenführung mit dem eingekerbten Teil am Rahmen ausrichten. Die Farbbandkassette aus dieser Position eindrücken, bis sie hörbar einrastet. Das Farbband zwischen dem Druckkopf und dem Farbband-Trenner einführen. Sicherstellen, daßkein Farbband über den Farbband-Trenner herausragt.
- ⑤ Um Schlaufen im Farbband aufzuwickeln, den Farbbandzuführknopf der Farbbandkassette in Pfeilrichtung drehen.
- ⑥ Zum Anbringen der Frontabdeckung die Ausbauschritte in umgekehrter Reihenfolge ausführen.

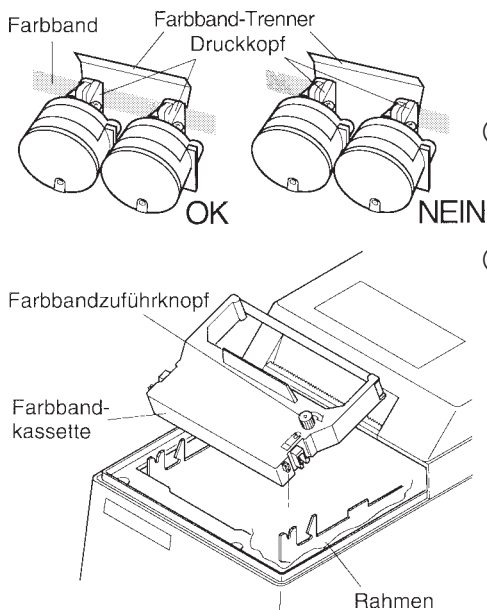
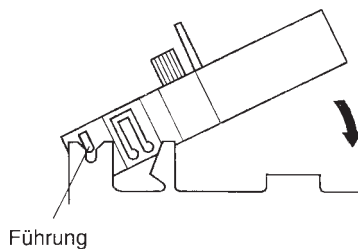

1-2. SP347

Frontabdeckung

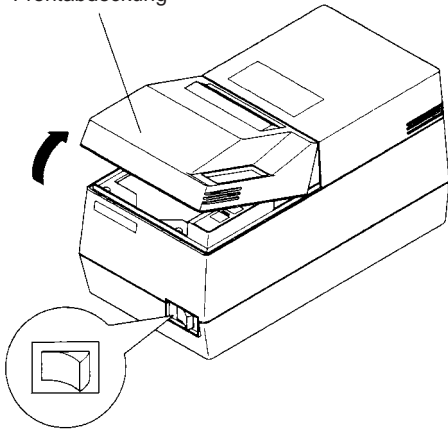

Netzschalter aus

Abb. 1-3 Abnehmen der Frontabdeckung (SP347)

- ① Den Netzschalter des Druckers in Aus-Stellung stellen.
- ② Zum Abnehmen der Frontabdeckung diese ca. 3 cm anheben, und nach vorne ziehen.

HINWEIS: Nicht den Druckkopf sofort nach dem Drucken berühren, da er sehr heiß sein kann.

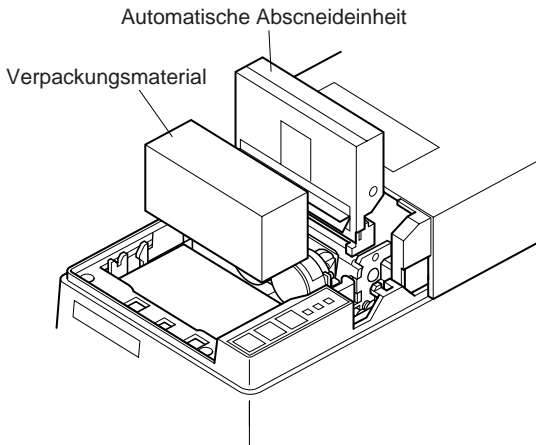

Automatische Abschneideeinheit

Verpackungsmaterial

- ③ Die automatische Abschneideeinheit anheben und in vertikale Position stellen, wie in der Abbildung 1-4 gezeigt.
- ④ Das Verpackungsmaterial entfernen.

Abb. 1-4 Die automatische Abschneideeinheit anheben, und das Verpackungsmaterial entfernen (SP347)

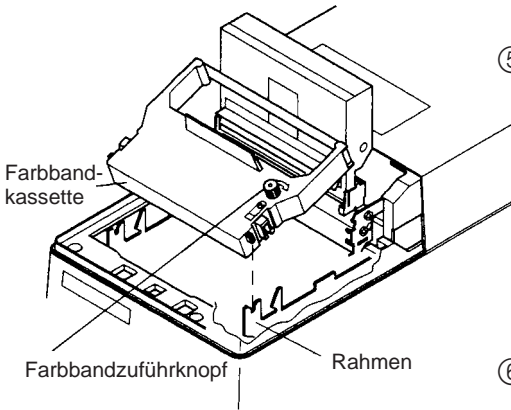

- ④ Um Schlaufen im Farbband aufzuwickeln, den Farbbandzuführknopf der Farbbandkassette in Pfeilrichtung drehen.
- ⑤ Die Farbbandkassette mit dem gekerbten Teil am Rahmen ausrichten. Die Farbbandkassette aus dieser Position bis zum hörbaren Einrasten eindrücken. Das Farbband zwischen dem Druckkopf und dem Farbband-Trenner einführen. Sicherstellen, daß kein Farbband über den Farbband-Trenner herausragt.
- ⑥ Um Schlaufen im Farbband aufzuwickeln, den Farbbandzuführknopf der Farbbandkassette in Pfeilrichtung drehen.



Abb. 1-5 Einlegen der Farbbandkassette (SP347)

- ⑦ Die automatische Abschneideeinheit absenken, und die Frontabdeckung anbringen. Zum Anbringen die Ausbauschritte in umgekehrter Reihenfolge ausführen.

2. EINLEGEN DES PAPIERS

2-1. SP317

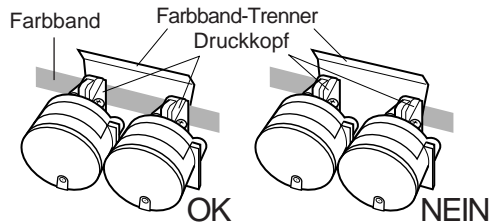
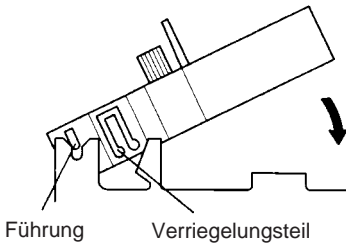

Abb. 2-1 Entfernen der Rückabdeckung (SP317)

- ① Den Netzschalter des Druckers in Aus-Stellung stellen.
- ② Den DIP-Schalter 2-4 entsprechend der Breite des verwendeten Papiers einstellen. (Die Einstellung der DIP Schalter finden Sie im Installationshandbuch.)

| DIP-Schalter | ON | OFF |
|--------------|-----------|-----------|
| 2-4 | 3,25 Zoll | 2,25 Zoll |
| | 3,0 Zoll | |

(Alle Schalter in der DIP-Schalterleiste sind ab Werk auf "ON" gestellt.)

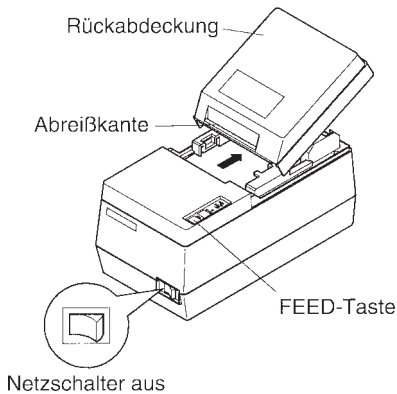
- ③ Zum Entfernen der Rückabdeckung diese ca. 3 cm anheben und nach hinten drücken.



Abb. 2-2 Anbringen der Papierrollenhalter (SP317)

- ④ Je nach der Breite des Papiers (2,25 oder 3 Zoll) die Papierrollenhalter auf die vorgeschriebene Position ausrichten.

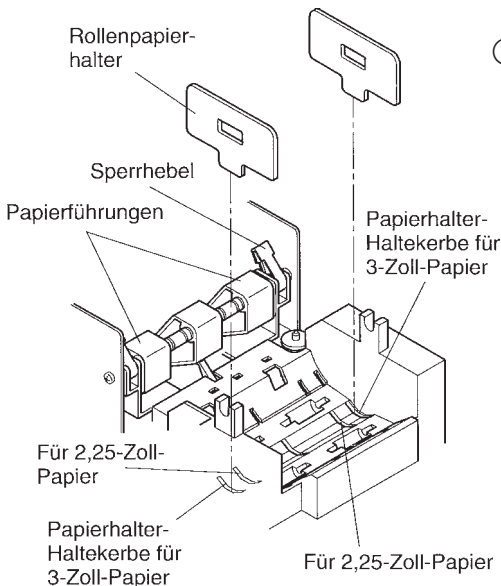

Abb. 2-3 Einstellung der Papierführung (SP317)

- ⑤ Stellen Sie die linke und rechte Papierführung ein. Lassen Sie einen 0,5 mm breiten Abstand zwischen Papierführung und Papierkante und stellen Sie den Sperrhebel fest.
 - Indem Sie den Sicherungsring einsetzen, der der Rille der Papierführungswelle in Abb. 2-3 entspricht, legen Sie die Position für die Papierführung fest.

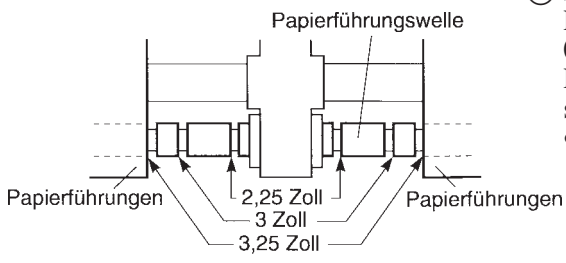

Abb. 2-4 Einlegen des Papiers (SP317)

- ⑥ Den Netzschalter des Druckers in Ein-Stellung stellen.
- ⑦ Schneiden Sie die Vorderkante des Rollenpapiers in einer geraden Linie ab.

Wenn die Vorderkante des Papiers mit einem Aufkleber etc. festgeklebt ist, ziehen Sie den Aufkleber ab. Wenn Klebstoff auf dem Papier verbleibt, kann er an der Walze haften und Fehleinzug bewirken.
- ⑧ Halten Sie das Rollenpapier wie in der Abbildung gezeigt, führen Sie das Oberende des Papiers unter der Papierführung so weit wie möglich ein, und drücken Sie die FEED-Taste am Bedienfeld, um das Papier einzuziehen.
- ⑨ Wenn die Vorderkante des Papiers aus dem Drucker ausgegeben wird, lassen Sie die FEED-Taste los. Danach setzen Sie das Rollenpapier auf die Rollenpapierwalze und setzen Sie die Rollenpapierwalze auf den Wellenhalter.
- ⑩ Führen Sie die Oberkante des Papiers in den Abreißkantenschlitz ein, und bringen dann die Rückabdeckung an, indem Sie die Ausbauschritte von Schritt ③ oben in umgekehrter Reihenfolge ausführen.

HINWEIS: Wenn die Papierendmarkierung auf dem Papier erscheint, das Rollenpapier austauschen, bevor es zu Ende geht.

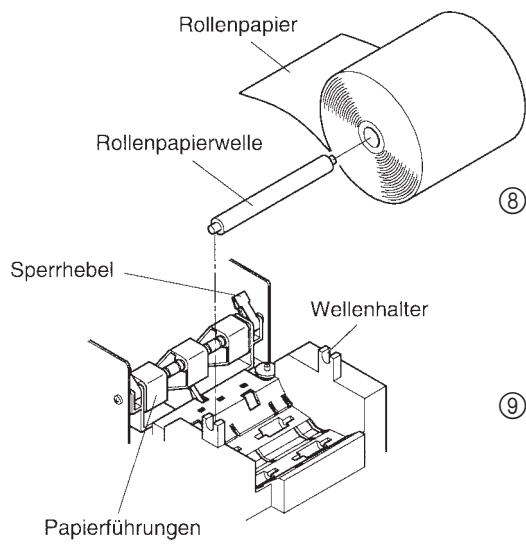
2-2. SP347

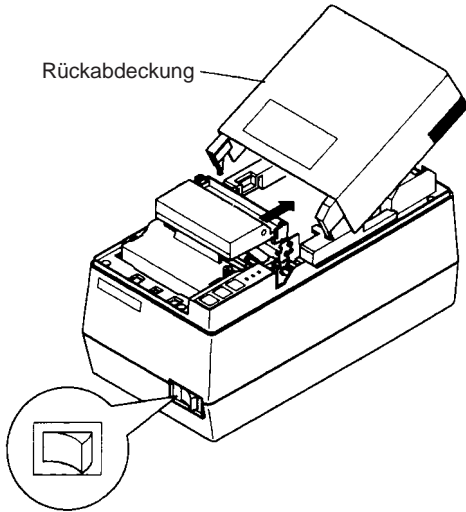

Netzschalter aus

- ① Den Netzschalter des Druckers in Aus-Stellung stellen.
- ② Zum Entfernen der Frontabdeckung diese ca. 3 cm anheben und nach vorne ziehen.

HINWEIS: Nicht den Druckkopf sofort nach dem Drucken berühren, da er sehr heiß sein kann.

- ③ Zum Entfernen der Rückabdeckung diese ca. 3 cm anheben und nach hinten drücken.

Abb. 2-5 Abnehmen der Rückabdeckung (SP347)

- ④ Den DIP-Schalter 2-4, den Rollenpapierhalter und die Einstellhebelposition entsprechend der Breite des verwendeten Papiers einstellen.
 - Die DIP-Schalterstellungen sind der Aufstallanleitung zu entnehmen.
 - Wenn Sie die Normalposition des Einstellhebels nicht kennen, senken Sie den Einstellhebel so weit wie möglich (an der Rückabdeckungsseite) ab, und ziehen ihn dann um zwei Stellungen nach oben. Diese Stellung ist die Normalposition A.

| Papier | | DIP-Schalter 2-4 (Abb. 4-1) | Einstellhebel- position (Abb. 2-6) | Rollenpapierhalter (Abb. 2-7) |
|--------------|----------------|--------------------------------|---------------------------------------|----------------------------------|
| Papierbreite | Dicke | | | |
| 2,25 Zoll | 1 Blatt Papier | OFF | A | Verwendet (Innenrille) |
| | Druckerpapier | OFF | B | Verwendet (Innenrille) |
| 3,0 Zoll | 1 Blatt Papier | ON | A | Verwendet (Außenrille) |
| | Druckerpapier | ON | B | Verwendet (Außenrille) |
| 3,25 Zoll | 1 Blatt Papier | ON | A | Nicht verwendet |
| | Druckerpapier | ON | B | Nicht verwendet |

**A: Ein Blatt Papier
(Normalposition)
B: Kopierpapier**



Abb. 2-6 Position des Einstellhebels (SP347)



Abb. 2-7 Anbringen der Rollenpapierhalter (SP347)

- ⑤ Stellen Sie die linke und rechte Papierführung ein. Lassen Sie einen 0,5 mm großen Abstand zwischen der Papierführung und der Kante des Papiers und befestigen Sie den Sperrhebel.

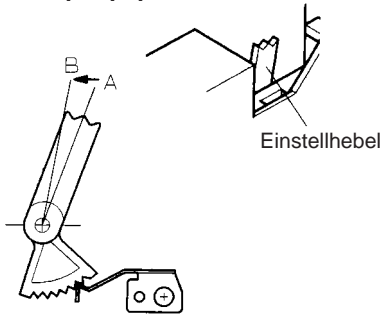
- Indem Sie den Sicherungsring einsetzen, der der Rille der Papierführungswelle in Abb. 2-8 entspricht, legen Sie die Position für die Papierführung fest.

- ⑥ Heben Sie die automatische Abschneideinheit an, und stellen Sie sie in senkrechte Stellung wie in der Abbildung 2-9 gezeigt.

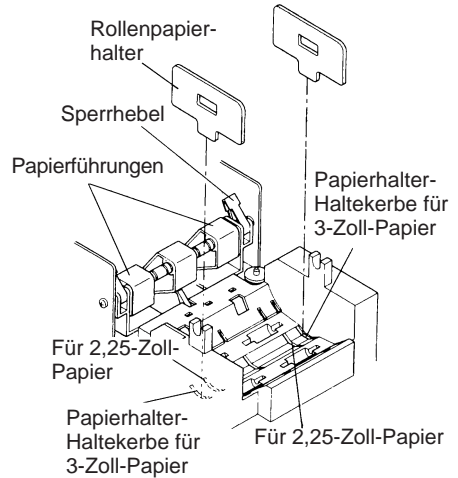

Abb. 2-8 Rollenpapierführung (SP347)



Abb. 2-9 Die automatische Abschneideinheit anheben (SP347)

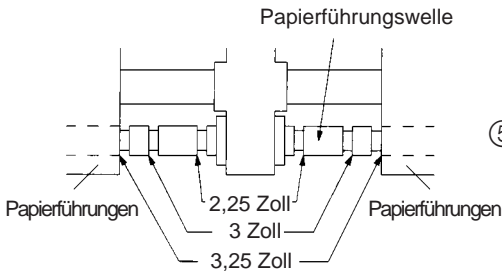

Abb. 2-10 Papier einlegen (SP347)

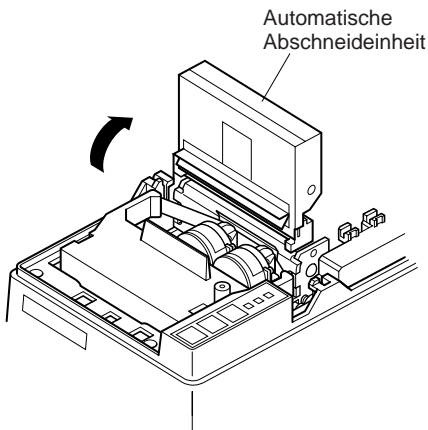

Abb. 2-11 Papier in die automatische Abschneideeinheit legen (SP347)

- ⑦ Den Netzschalter des Druckers in Ein-Stellung stellen.
- ⑧ Schneiden Sie die Vorderkante des Rollenpapiers in einer geraden Linie ab.
 - Wenn die Vorderkante des Papiers mit einem Aufkleber etc. festgeklebt ist, ziehen Sie den Aufkleber ab. Wenn Klebstoff auf dem Papier verbleibt, kann er an der Walze anhaften und Fehleinzug bewirken.
- ⑨ Beachten Sie die Wickelrichtung des Rollenpapiers, und setzen Sie das Papier ein, bis es unter der Führung stoppt.
- ⑩ Drücken Sie die FEED-Taste (Papiervorschub) am Bedienfeld. Lassen Sie die Taste los, wenn das Rollenpapier 10 cm aus dem Papierauslauf ausgegeben worden ist.
- ⑪ Setzen Sie die Rollenpapierwelle in die Papierrolle ein, und setzen Sie diese in den Wellenhalter ein.
- ⑫ Führen Sie die Oberkante des Rollenpapiers in den Schlitz der automatischen Abschneideeinheit ein.
 - Bei Verwendung von Durchschlagpapier setzen Sie nur das Originalpapier (obere Papier) in den Schlitz in der automatischen Abschneideeinheit ein. Führen Sie das Kopierpapier (das untere Papier) zwischen Druckwalze und automatischer Abschneideeinheit ein. In diesem Fall ist der Rückwickler PW300 Sonderzubehör erforderlich, um das Durchschlagpapier aufzuwickeln. Anbringen des Rückwicklers siehe seine Bedienungsanleitung.

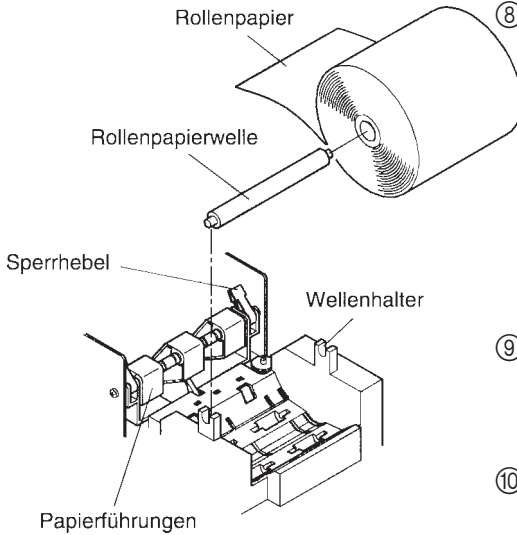

Abb. 2-12 Einsetzen des Papiers in den automatischen Abscheider (bei Verwendung von Durchschlagpapier) (SP347)

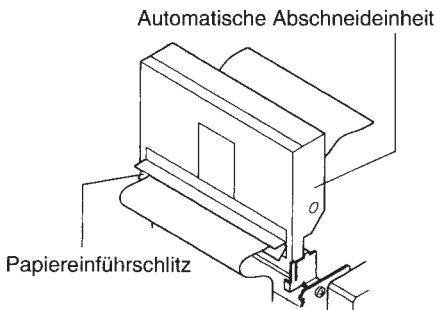

Abb. 2-13 Papierauslaß an der Frontabdeckung (SP347)

2-3. Entfernen des Rollenpapiers

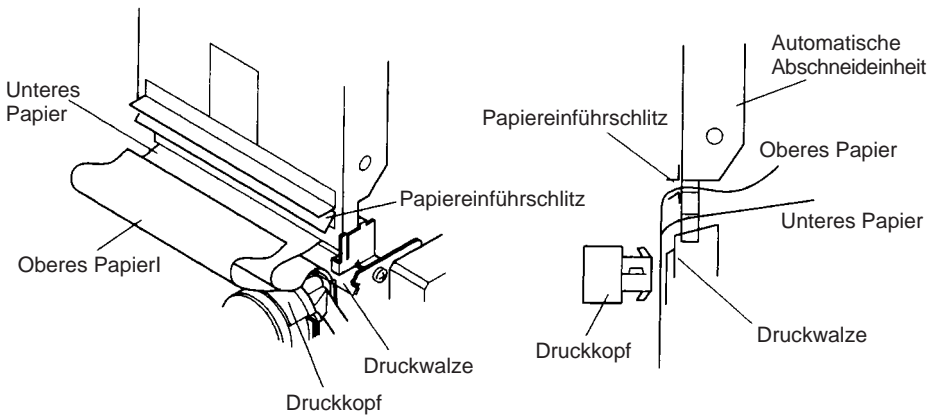
Nehmen Sie die Rückabdeckung ab, und schneiden Sie das Papier in der Nähe der Papierführung ab. Dann drücken Sie die FEED-Taste, um den Rest des Papiers auszugeben, der noch in der Einheit ist.

Wenn das Papier verbraucht ist, wird ein Tonsignal bestehend aus zweimal vier Tönen ausgegeben.

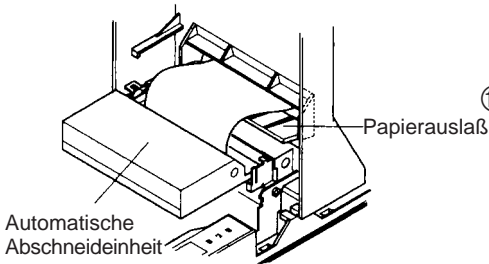
HINWEIS 1. Durch Drücken der FEED-Taste wird der Rest des noch im Drucker befindlichen Papiers ausgegeben. (Wenn Sie das Papier mit der Hand entnehmen, kann es knittern oder verrutschen und einen Papierstau bewirken.)

HINWEIS 2. Wenn die Papier-Verbraucht-Markierung auf dem Papier erscheint, tauschen Sie die Rolle aus, bevor das Papier ganz zu Ende ist.

- ⑬ Ziehen Sie die Kante des Papiers-tau, um Schlaufen zu beseitigen, und senken Sie dann die automatische Abscheideeinheit ab.
- ⑭ Führen Sie das Papier durch den Papierauslaß in der Frontabdeckung, und setzen Sie dann die Frontabdeckung wieder auf, indem Sie die Ausbauschritte in umgekehrter Reihenfolge ausführen.
- ⑮ Zum Einbauen der Rückabdeckung die Ausbauschritte in umgekehrter Reihenfolge ausführen.

3. BEDIENFELD



Abb. 3-1 Bedienfeld

① Taste ON LINE

Schaltet den Drucker zwischen On-line und Off-line Betrieb um. Bei jedem Umschalten zwischen On-line und Off-line wird ein kurzer Piepton ausgegeben (Umschalten ist nur möglich, wenn Papier im Drucker eingelegt ist.)

② FEED-Schalter

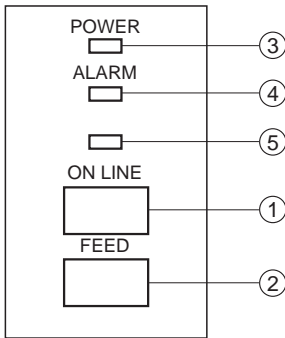
- Wenn dieser Schalter gedrückt und dann innerhalb von 0,5 s losgelassen wird, wird das Papier um eine Zeile vorgeschoben.
- Wenn dieser Schalter länger als 0,5 s gedrückt gehalten wird, wird das Papier kontinuierlich vorgeschoben. (Der obige Vorschubvorgang ist sowohl im On-line als auch im Off-line Betrieb möglich.)

③ Netzlämpchen POWER (grüne LED)

- Leuchtet auf, wenn der Drucker mit Netzstrom versorgt wird.

④ Warnlämpchen ALARM (rote LED)

- Leuchtet auf, wenn das Papier verbraucht ist.

Wenn das Papier verbraucht ist, legen Sie eine neue Rolle ein und drücken die Taste ON LINE.

- Blinkt, wenn die Frontabdeckung offen ist oder ein mechanischer Fehler (Motorblockierung etc.) vorliegt. In diesem Fall wird ein kurzer Piepton gefolgt von einem langen Piepton ausgegeben.

Setzen Sie die Frontabdeckung richtig auf, und drücken Sie die Taste ON LINE. Wenn das Tonsignal weiter ertönt und die ALARM-Leuchte blinkt, heißt dies, daß ein mechanischer Fehler aufgetreten ist. Finden Sie die Ursache des Fehlers, und schalten Sie den Drucker aus und anschließend wieder ein, um einen Rückstellung auszuführen.

(Bei mechanischen Störungen werden die Daten nicht gelöscht, auch wenn der Drucker ausgeschaltet wird.)

⑤ Lämpchen ON LINE (grüne LED)

LED leuchtet: Drucker im On-line-Betrieb

LED erloschen: Drucker im Off-line-Betrieb

LED blinkt: Validierungsdruck ist gewählt

Wenn alle Lämpchen ③ bis ⑤ gleichzeitig leuchten und der Signalton kontinuierlich erklingt, liegt ein CPU-Fehler vor. In diesem Fall das Gerät aus- und dann wieder einschalten. Wenn das Gerät ausgeschaltet wird, werden die Daten gelöscht.

INDICE

| | |
|---|----|
| 1. CARICAMENTO DELLA CARTUCCIA DEL NASTRO | 38 |
| 1-1. SP317 | 38 |
| 1-2. SP347 | 39 |
| 2. CARICAMENTO DELLA CARTA | 41 |
| 2-1. SP317 | 41 |
| 2-2. SP347 | 43 |
| 2-3. Rimozione della carta in rotolo | 46 |
| 3. PANNELLO DI CONTROLLO | 47 |
| APPENDICE | 49 |

L'Appendice appare solo nella sezione in inglese di questo manuale.

1. CARICAMENTO DELLA CARTUCCIA DEL NASTRO

1-1. SP317

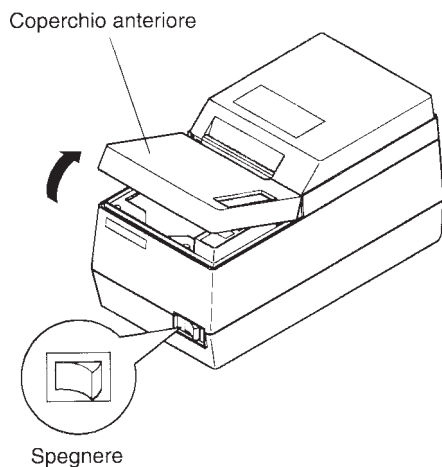

Fig. 1-1 Rimozione del coperchio anteriore (SP317)

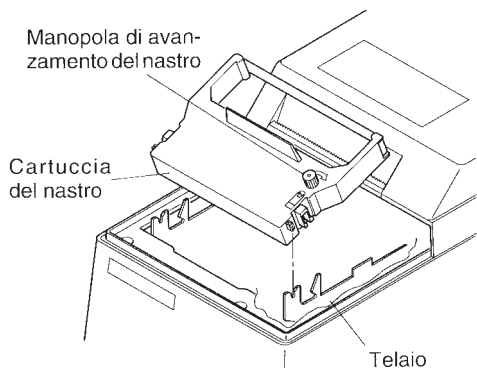
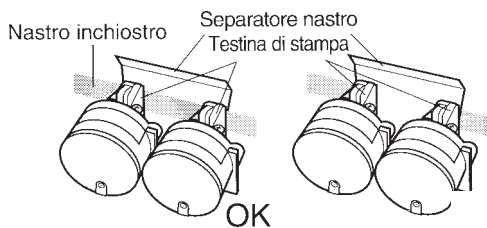
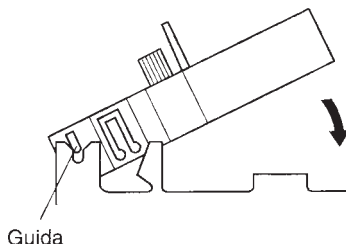

Fig. 1-2 Caricamento della cartuccia del nastro (SP317)

- ① Regolare l'interruttore di alimentazione della stampante sulla posizione di spegnimento.
- ② Per rimuovere il coperchio anteriore sollevarlo di circa 3 cm e tirarlo in avanti.

NOTA: Non toccare la testina di stampa subito dopo la stampa perché può essere molto calda.

- ③ Per eliminare allentamenti del nastro girare la manopola di avanzamento del nastro sulla cartuccia del nastro in direzione della freccia.
- ④ Allineare la guida della cartuccia del nastro con la parte incassata del telaio. Inserire la cartuccia del nastro da quella posizione fino a quando si sente uno scatto. Inserire il nastro inchiostro tra la testina di stampa e il separatore nastro. Assicurarsi che il nastro inchiostro non sporga oltre il separatore nastro.
- ⑤ Per eliminare allentamenti nel nastro girare la manopola di avanzamento del nastro sulla cartuccia del nastro in direzione della freccia.
- ⑥ Per installare il coperchio anteriore eseguire all'inverso il procedimento usato per la rimozione.



1-2. SP347

Coperchio anteriore

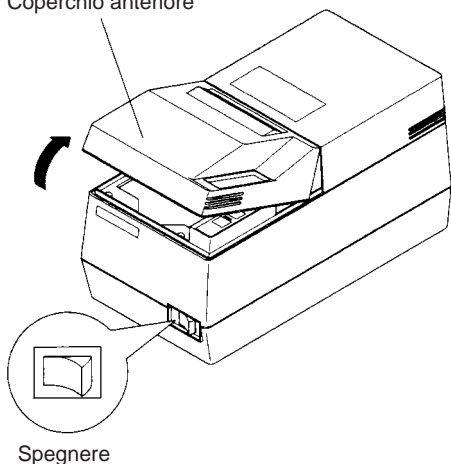

- ① Regolare l'interruttore di alimentazione della stampante sulla posizione di spegnimento.
- ② Per rimuovere il coperchio anteriore sollevarlo di circa 3 cm e tirarlo in avanti.

NOTA: Non toccare la testina di stampa subito dopo la stampa perché può essere molto calda.

Fig. 1-3 Rimozione del coperchio anteriore (SP347)

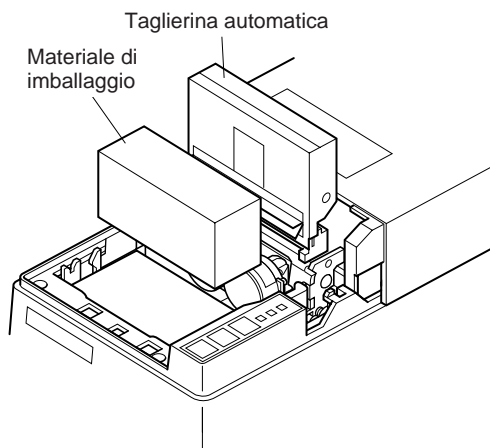

- ③ Sollevare la taglierina automatica e porla in posizione verticale, come mostrato nella Fig. 1-4.
- ④ Rimuovere il materiale di imballaggio.

Fig. 1-4 Sollevare la taglierina automatica e rimuovere il materiale di imballaggio (SP347)

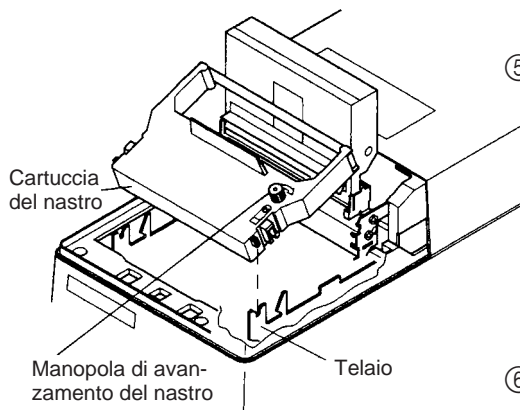

- ④ Per eliminare allentamenti del nastro girare la manopola di avanzamento del nastro sulla cartuccia del nastro in direzione della freccia.
- ⑤ Allineare la guida della cartuccia del nastro con la parte incassata del telaio. Inserire la cartuccia del nastro da quella posizione fino a quando si sente uno scatto. Inserire il nastro inchiostro tra la testina di stampa e il separatore nastro. Assicurarsi che il nastro inchiostro non sporga oltre il separatore nastro.
- ⑥ Per eliminare allentamenti nel nastro girare la manopola di avanzamento del nastro sulla cartuccia del nastro in direzione della freccia.

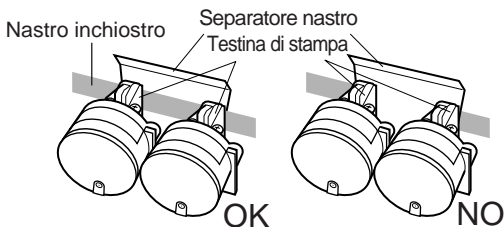
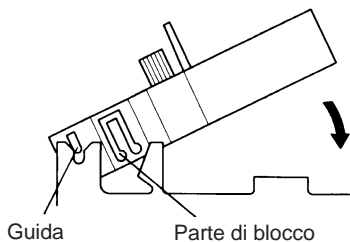

Fig. 1-5 Caricamento della cartuccia del nastro (SP347)

- ⑦ Abbassare la taglierina automatica e installare il coperchio anteriore eseguendo all'inverso il procedimento usato per la rimozione.

2. CARICAMENTO DELLA CARTA

2-1. SP317

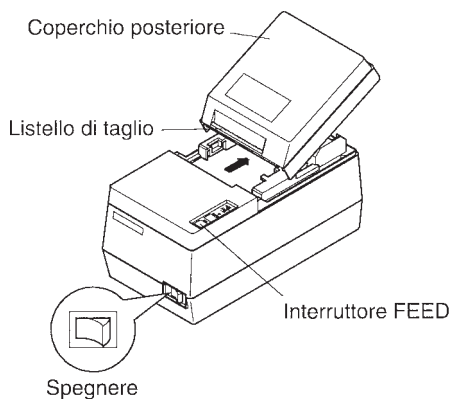

Fig. 2-1 Rimozione del coperchio posteriore (SP317)

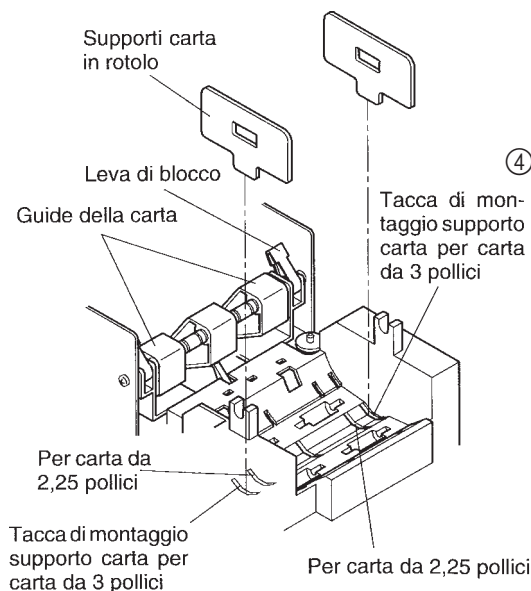

Fig. 2-2 Montaggio dei supporti per carta in rotolo (SP317)

- ① Regolare l'interruttore di alimentazione della stampante sulla posizione di spegnimento.
- ② Regolare l'interruttore DIP 2-4 in base alla larghezza della carta usata. (Consultare il Manuale di Installazione per le impostazioni degli interruttori DIP).

| Interruttori DIP | ON | OFF |
|------------------|--------------|--------------|
| 2-4 | 3,25 pollici | 2,25 pollici |
| | 3,0 pollici | |

(Tutti gli interruttori nel gruppo di interruttori DIP sono stati predisposti in fabbrica sulla posizione "ON".)

- ③ Per rimuovere il coperchio posteriore, sollevarlo di circa 3 cm e spingerlo indietro.

- ④ A seconda della larghezza della carta (2,25 o 3 pollici), allineare i supporti della carta in rotolo alle posizioni specificate.

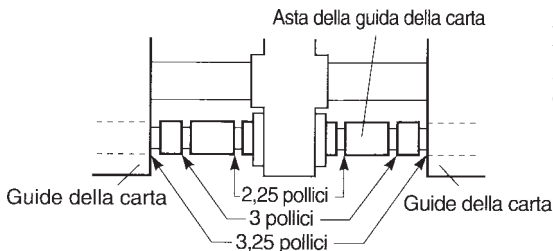

Fig. 2-3 Regolazione delle guide della carta (SP317)

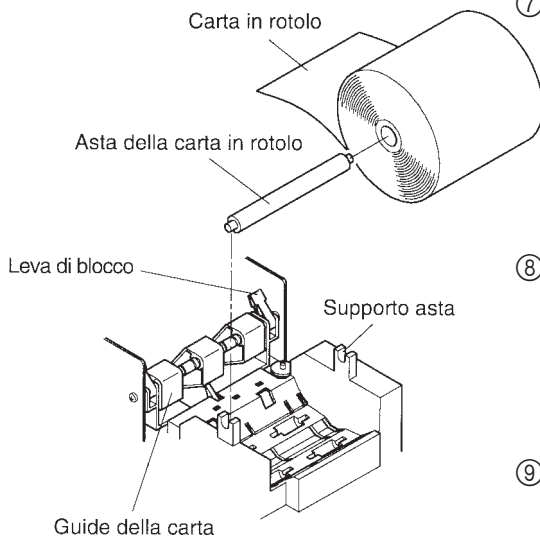

Fig. 2-4 Caricamento della carta (SP317)

- ⑤ Regolare le guide della carta sinistra e destra.

Lasciare uno spazio di 0,5 mm tra la guida della carta e il bordo della carta e fissare la leva di blocco.

- Quando si inserisce l'anello di fermo corrispondente alla scanalatura sull'asta delle guide della carta mostrata nella Fig. 2-3, quella sarà la posizione quando si fissa la guida della carta.

- ⑥ Regolare l'interruttore di alimentazione della stampante sulla posizione di accensione.

- ⑦ Tagliare la parte iniziale della carta in rotolo su una linea dritta.

Se la parte iniziale della carta è fissata con un'etichetta, ecc., rimuovere la parte adesiva dell'etichetta. Se rimane dell'adesivo sulla carta, si può appiccicare al rullo della stampante, causando errori di avanzamento della carta.

- ⑧ Tenere il rotolo di carta come mostrato nell'illustrazione e inserire la parte superiore della carta sotto la guida della carta il più possibile, quindi premere l'interruttore "FEED" sul pannello di controllo per far avanzare la carta.

- ⑨ Quando la parte iniziale della carta fuoriesce dalla stampante, rilasciare l'interruttore "FEED". Inserire quindi la carta sull'asta della carta in rotolo e collocare l'asta della carta in rotolo sul supporto asta.

- ⑩ Inserire la parte iniziale della carta nella fessura del listello di taglio, quindi montare il coperchio posteriore eseguendo all'inverso il procedimento usato per la rimozione del coperchio posteriore al punto ③ sopra.

NOTA: Quando appare sulla carta il segno di fine carta, sostituire il rotolo di carta prima che si esaurisca.

2-2. SP347

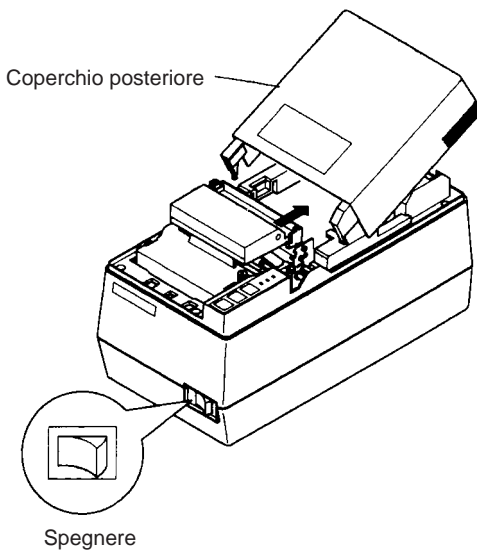

① Regolare l'interruttore di alimentazione della stampante sulla posizione di spegnimento.

② Per rimuovere il coperchio anteriore sollevarlo di circa 3 cm e tirarlo in avanti.

NOTA: Non toccare la testina di stampa subito dopo la stampa perché può essere molto calda.

③ Per rimuovere il coperchio posteriore sollevarlo di circa 3 cm e tirarlo indietro.

Fig. 2-5 Rimozione del coperchio posteriore (SP347)

④ Regolare l'interruttore DIP 2-4, il supporto carta in rotolo e la posizione della leva di regolazione in base alla larghezza e allo spessore del rotolo di carta impiegato.

- Fare riferimento al manuale di installazione per la posizione dell'interruttore DIP.
- Se non si conosce la posizione standard della leva di regolazione, abbassare la leva di regolazione il più possibile (verso il coperchio posteriore) e quindi tirarla in su di due scatti. Questa è la posizione standard A

| Carta | | Interruttore DIP 2-4 (Fig. 4-1) | Posizione leva di regolazione (Fig. 2-6) | Supporto carta in rotolo (Fig. 2-7) |
|-----------------|-------------------|------------------------------------|---|--|
| Larghezza carta | Spessore | | | |
| 2,25 pollici | 1 foglio di carta | OFF | A | Usato (scanalatura interna) |
| | Carta stampante | OFF | B | Usato (scanalatura interna) |
| 3,0 pollici | 1 foglio di carta | ON | A | Usato (scanalatura esterna) |
| | Carta stampante | ON | B | Usato (scanalatura esterna) |
| 3,25 pollici | 1 foglio di carta | ON | A | Non usato |
| | Carta stampante | ON | B | Non usato |

**A: Un foglio di carta
(posizione standard)**
B: Carta carbone

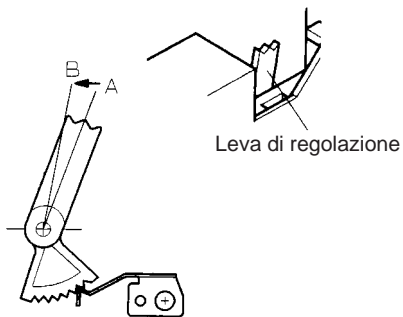

Fig. 2-6 Posizione della leva di regolazione (SP347)

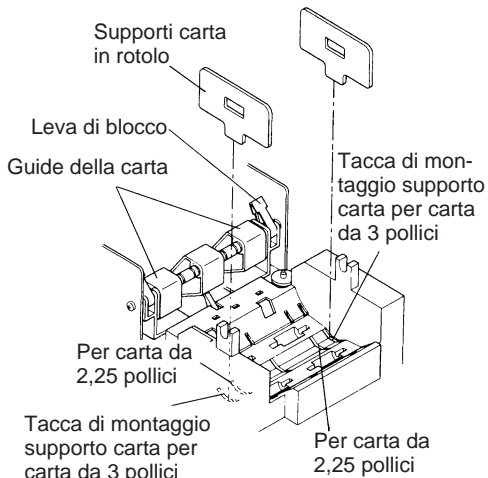

Fig. 2-7 Montaggio dei supporti carta in rotolo (SP347)

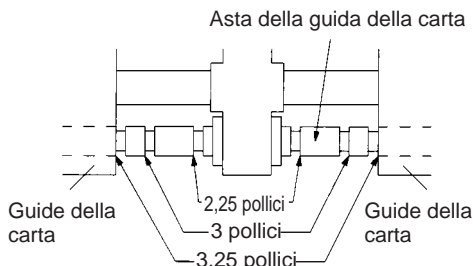

Fig. 2-8 Guida della carta in rotolo (SP347)

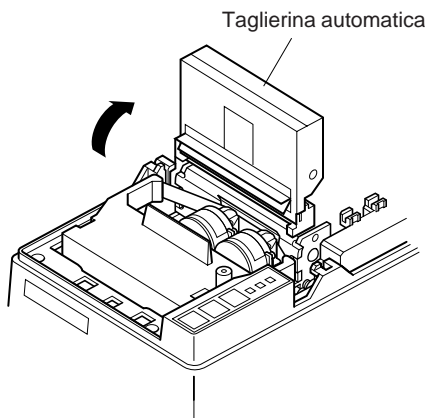

Fig. 2-9 Sollevare la taglierina automatica (SP347)

⑤ Regolare le guide della carta sinistra e destra.

Lasciare uno spazio di 0,5 mm tra la guida della carta e il bordo della carta e fissare la leva di blocco.

- Quando si inserisce l'anello di fermo corrispondente alla scanalatura sull'asta delle guide della carta mostrata nella Fig. 2-8, quella sarà la posizione quando si fissa la guida della carta.

⑥ Sollevare la taglierina automatica e porla in posizione verticale, come mostrato nella Fig. 2-9.

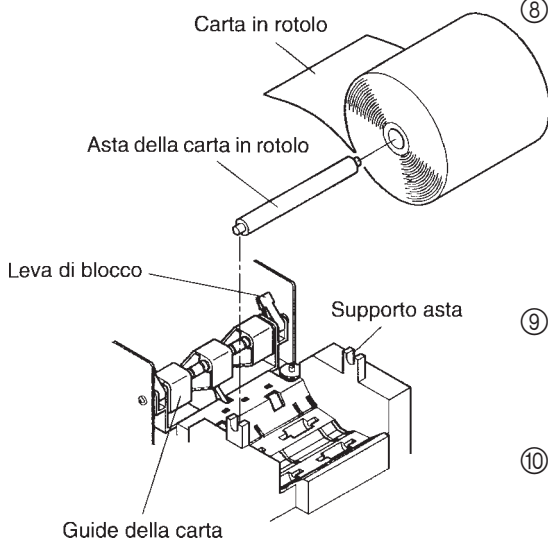

Fig. 2-10 Caricamento della carta (SP347)

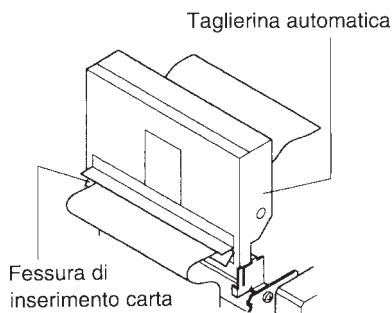

Fig. 2-11 Inserimento della carta nella taglierina automatica (SP347)

⑦ Regolare l'interruttore di alimentazione della stampante sulla posizione di accensione.

⑧ Tagliare la parte iniziale della carta in rotolo su una linea diritta.

- Se la parte iniziale della carta è fissata con un'etichetta, ecc., rimuovere la parte adesiva dell'etichetta. Se rimane dell'adesivo sulla carta, si può appiccicare al rullo della stampante, causando errori di avanzamento della carta.

⑨ Osservare la direzione di avvolgimento della carta in rotolo e inserire la carta sotto la guida il più possibile.

⑩ Premere l'interruttore "FEED" (avanzamento carta) sul pannello di controllo.

Rilasciare l'interruttore quando la carta è avanzata di 10 cm dall'uscita della carta.

⑪ Inserire la carta sull'asta della carta in rotolo e collocare l'asta della carta in rotolo sul supporto asta.

⑫ Inserire la parte iniziale della carta nella fessura della taglierina automatica.

- Quando si usa carta carbone, inserire solo l'originale (foglio superiore) nella fessura della taglierina automatica. Inserire la carta della copia (foglio inferiore) tra il rullo e la taglierina automatica. In questo caso è necessario il riavvolgitore PW300 (opzionale) per riavvolgere la carta di copia. Fare riferimento al manuale di istruzioni del riavvolgitore per il metodo di impostazione.

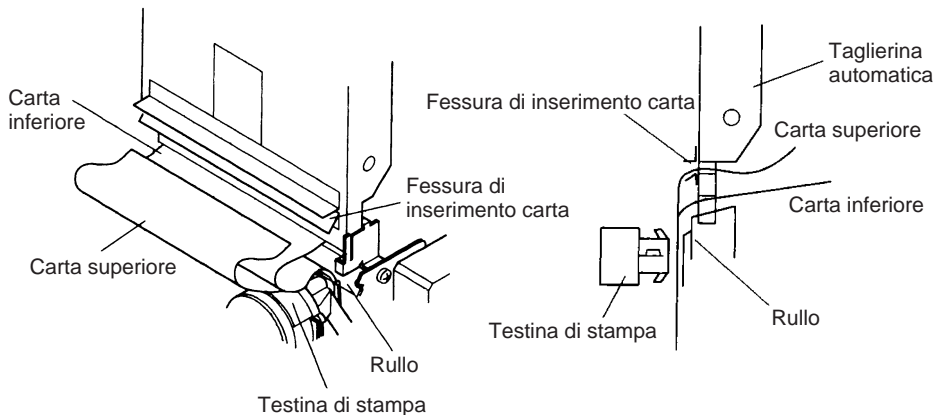

Fig. 2-12 Inserimento della carta nella taglierina automatica (quando si usa carta carbone) (SP347)

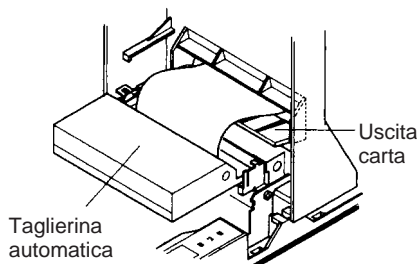

Fig. 2-13 Uscita della carta sul coperchio anteriore (SP347)

- ⑬ Tirare il bordo della carta per rimuovere eventuali allentamenti e quindi abbassare la taglierina automatica.
- ⑭ Inserire la carta attraverso l'uscita carta sul coperchio anteriore e quindi rimettere il coperchio anteriore eseguendo all'inverso il procedimento usato per la rimozione.
- ⑮ Installare il coperchio posteriore eseguendo all'inverso il procedimento usato per la rimozione.

2-3. Rimozione della carta in rotolo

Rimuovere il coperchio posteriore e quindi tagliare la carta vicino al retro della guida della carta. Quindi premere l'interruttore "FEED" per far fuoriuscire il resto della carta rimanente nell'unità.

Quando la carta finisce, un cicalino suona 4 volte per ciclo per 2 cicli.

NOTA 1: Premere l'interruttore "FEED" per rimuovere la carta rimanente nella stampante. (Se si rimuove manualmente la carta, la carta può spiegazzarsi o scivolare causando un inceppamento.)

NOTA 2: Quando appare sulla carta il segno di fine carta, sostituire il rotolo di carta prima che si esaurisca.

3. PANNELLO DI CONTROLLO

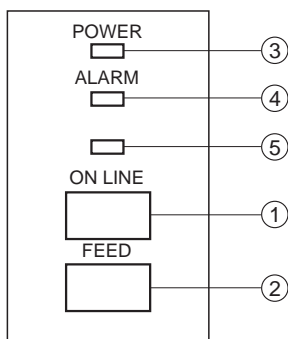

Fig. 3-1 Pannello di controllo

- ① Interruttore “ON LINE”
Alterna lo stato dello stampante tra “ON LINE” e “OFF LINE”. Quando la stampante alterna tra “ON LINE” e “OFF LINE”, il cicalino emette un breve segnale acustico. (la commutazione “ON LINE” e “OFF LINE” è possibile solo quando la carta è caricata nella stampante.)
- ② Interruttore “FEED”
- Quando questo interruttore viene premuto per più di mezzo secondo, la carta avanza continuamente. (L’operazione di avanzamento carta sopra descritta è possibile in entrambi i modi “ON LINE” e “OFF LINE”.)

- ③ Spia “POWER” (LED verde)
- Si illumina quando la stampante è accesa.
- ④ Spia “ALARM” (LED rosso)
- Si illumina quando la carta è esaurita.
Se la carta finisce, caricare un nuovo rotolo e quindi premere l’interruttore “ON LINE”.
 - Lampeggia quando il coperchio anteriore è aperto o quando si verifica un errore meccanico (blocco del motore, ecc.). Il cicalino emette un segnale acustico breve seguito da uno lungo.
Montare correttamente il coperchio anteriore e premere l’interruttore “ON LINE”. Se il cicalino suona ancora e la spia “ALARM” lampeggia, vuol dire che si è verificato un errore meccanico. Localizzare la causa dell’errore e spegnere e riaccendere la stampante per inicializzarla.
(Nel caso di un errore meccanico, i dati non sono cancellati anche se si spegne l’unità.)
- ⑤ Spia “ON LINE” (LED verde)
- LED illuminato: La stampante è “ON LINE”.
LED spento: La stampante è “OFF LINE”.
LED lampeggiante: È selezionato il modo di stampa a convalida.
Quando tutte le spie da ③ a ⑤ si illumina contemporaneamente e il cicalino suona continuamente, si è verificato un errore CPU. Nel caso di un errore CPU spegnere la stampante e quindi riaccenderla. Quando si spegne la stampante i dati sono cancellati.

APPENDIX

Connectors and Signals (Serial Interface)

RS-232C

| Pin no. | Signal name | I/O direction | Function |
|----------|-------------------|---------------|--|
| 1 | F-GND | — | Frame ground |
| 2 | TXD | OUT | Transmitted data |
| 3 | RXD | IN | Received data |
| 4 | RTS | OUT | Data transmission request signal. This is always “SPACE” when the printer is turned on. |
| 5 | CTS | IN | This signal changes to “SPACE” when host computer is ready to transmit data. (In this instance, the printer does not check this signal.) |
| 6 | N/C | | Not connected |
| 7 | S-GND | — | Signal ground |
| 8 | N/C | | Not connected |
| 9-10 | N/C | | This pin is used when using the optional interface board. |
| 11 | RCH | OUT | This signal changes to “SPACE” when the printer is ready to receive data. (The signal line is same as pin 20.) |
| 12 | N/C | | Not connected. |
| 13 | S-GND | — | Signal ground |
| 14 | FAULT | OUT | When a printer error occurs (such as paper out, mechanical error, etc.), this signal is set to “MARK”. |
| 15 | Multi-printer TXD | OUT | Diode coupled TXD |
| 16 | Multi-printer DTR | OUT | Diode coupled DTR |
| 17 to 19 | N/C | | This pin is used when using the optional interface board. |
| 20 | DTR | OUT | Data terminal ready signal. When the printer is ready to receive data, this signal changes to “SPACE”. |
| 21-22 | N/C | | Not connected |
| 23 to 25 | N/C | | This pin is used when using the optional interface board. |

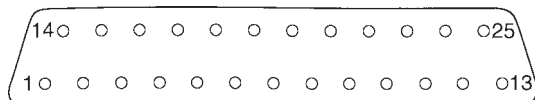

Serial interface connector

20 mA current loop (option)

| Pin no. | Signal name | I/O direction | Function |
|---------|-------------|---------------|---|
| 9 | TTY TXDR | — | Indicates the ground side of the data signal of 20 mA loop current. |
| 10 | TTY TXD | OUT | Transmitted data of 20 mA current loop. |
| 17 | TTY TXDR | — | Indicates the ground side of the data signal of 20 mA loop current. |
| 18 | TTY RXDR | — | Indicates the ground side of the data signal of 20 mA loop current. |
| 19 | TTY RXD | IN | Received data of 20 mA current loop. |
| 23 | TTY RXDR | — | Indicates the ground side of the data signal at 20mA loop current. |
| 24 | TTY TXD | OUT | Transmission data of 20 mA current loop. |
| 25 | TTY RXD | IN | Reception data of 20 mA current loop. |

RS-422A (option)

| Pin no. | Signal name | I/O direction | Function |
|---------|-------------|---------------|---|
| 9 | SD (+) | OUT | Transmitted data |
| 10 | SD (-) | OUT | Transmitted data |
| 17 | RD (+) | IN | Received data |
| 18 | RD (-) | IN | Received data |
| 19 | CS (+) | IN | When the host computer is set to standby for data transmission, this signal changes to "SPACE". (In this instance, the printer does not check the signal.) |
| 23 | CS (-) | IN | When the host computer is set to standby for data transmission, this signal changes to "SPACE". (In this instance, the printer does not check the signal.) |
| 24 | RS (+) | OUT | Data transmission request signal. When the printer is ready to receive data, this signal changes to "SPACE". |
| 25 | RS (-) | OUT | Data transmission request signal. When the printer is ready to receive data, this signal changes to "SPACE". |

Interface Connections (Serial Interface)

The following is a basic example of interface connections. (For interface connections, refer to the specifications for the respective interface.) An IBM PC type serial port is shown in below.

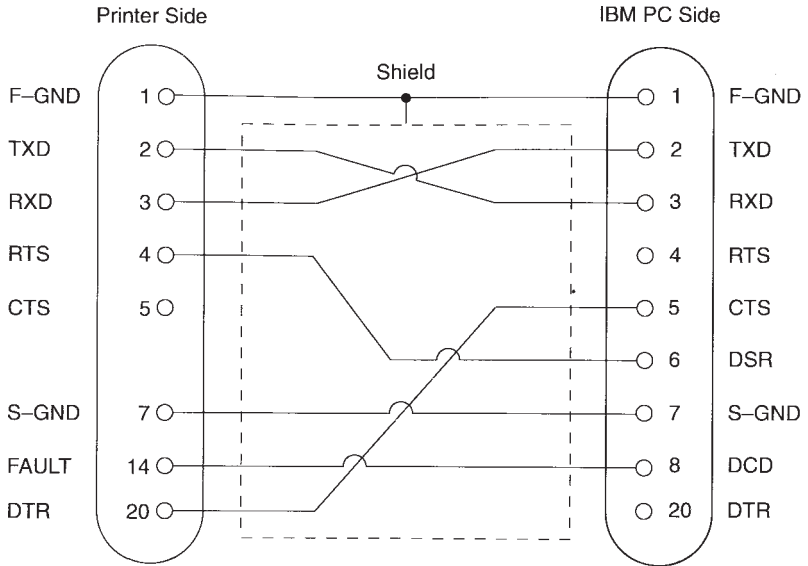

Example of interface connections for an IBM PC

Connectors and Signals (Parallel Interface)

| Pin No. | Signal Name | IN/OUT | Function |
|---------|----------------------------|--------|---|
| 1 | $\overline{\text{STROBE}}$ | IN | Signals when data is ready to be read. Signal goes from HIGH to LOW (for at least 0.5 microsec.) when the data is available. |
| 2-9 | DATA1-8 | IN | These signals provide the information of the first to eighth bits of parallel data. Each signal is at HIGH level for a logical 1 and at a LOW level for a logical 0. |
| 10 | $\overline{\text{ACK}}$ | OUT | A 9 microsecond LOW pulse acknowledges receipt of the data. |
| 11 | BUSY | OUT | When this signal goes to LOW, the printer is ready to accept data. When the printer is in one of the conditions below, "HIGH" is set. 1. Data is being entered. 2. Off line. 3. Error condition. |
| 12 | PAPER OUT | OUT | This signal is normally LOW. It will go to HIGH if the printer runs out of paper. |
| 13 | SELECTED | OUT | This signal is HIGH when the printer is online. |
| 14-15 | N/C | | Unused |
| 16 | SIGNAL GND | | Signal ground. |
| 17 | CHASSIS GND | | Chassis ground, isolated from logic ground. |
| 18 | +5VDC | | +5VDC (Max 50 mA) |
| 19-30 | GND | | Twisted pair return the signal to ground level. |
| 31 | $\overline{\text{RESET}}$ | IN | When this signal goes to LOW, the printer is reset to its power-on condition. |
| 32 | $\overline{\text{ERROR}}$ | OUT | This signal is normally HIGH. This signal goes to LOW to signal that the printer cannot print due to an error condition. |
| 33 | EXT GND | | External ground. |
| 34 | COMPULSION | OUT | Compulsion signal |
| 35 | N/C | - | Unused. |
| 36 | - | - | This signal is normally set to HIGH on the printer side. |

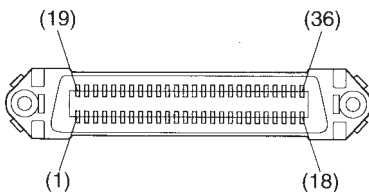

This connector mates with an Amphenol 57-30360 connector

Parallel interface connector (printer side)

Peripheral Unit Drive Circuit

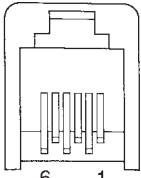

6-P modular jack connector

[Drive output 24V, max. 1.0 A]

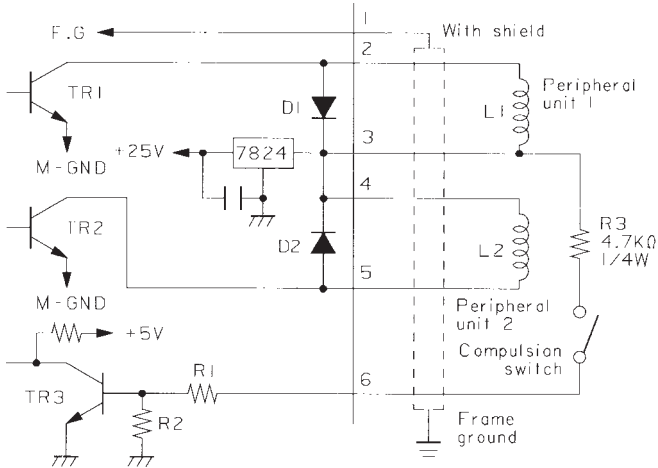

Drive circuit

Dot Alignment Adjust Mode

When the dot alignment adjust mode is entered, seven types of ruled lines are printed with the print timing being shifted by half each time, and an asterisk (*) is added at the currently specified position. To specify printing of a ruled line at a position different from that marked with the asterisk, press the ONLINE or the FEED button.

ONLINE: Select the printing status one line above when pressed once.

FEED: Select the printing status one line down when pressed once.

Dot Alignment Adjust Mode

|||||
|||||
|||||
|||||
|||||
|||||
|||||
|||||
|||||
|||||
|||||
|||||

|||||
|||||
|||||
|||||
|||||
|||||
|||||
|||||
|||||
|||||
|||||
|||||

|||||
|||||
|||||
|||||
|||||
|||||
|||||
|||||
|||||
|||||
|||||
|||||

* |||||
|||||
|||||
|||||
|||||
|||||
|||||
|||||
|||||
|||||
|||||
|||||

|||||
|||||
|||||
|||||
|||||
|||||
|||||
|||||
|||||
|||||
|||||
|||||

|||||
|||||
|||||
|||||
|||||
|||||
|||||
|||||
|||||
|||||
|||||
|||||

|||||
|||||
|||||
|||||
|||||
|||||
|||||
|||||
|||||
|||||
|||||
|||||

To reset the printing status, meaning to return the specified position to the default position (the fourth printing status from the top), press the FEED button while holding down the ONLINE button.

To exit the dot alignment adjust mode, press the ONLINE button, while holding down the FEED button. The dot alignment adjust mode setting is stored in the memory, a pattern using the selected setting, followed by "Adjust Completed" is printed, and the mode returns to the online mode.

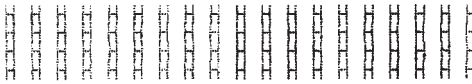
* 
Adjust Completed!

General Specifications

| | |
|--------------------------|---|
| Printing method: | Serial impact dot matrix |
| Print direction: | Bi-directional |
| Number of head pins: | 9 × 2 (Twin head) |
| Number of print columns: | 40 columns, 14.9 CPI 33 columns, 12.5 CPI 22 columns, 8.3 CPI |
| Character set: | ASCII 96 (characters) Special characters 64 Block graphics 64 IBM special characters 64 IBM block graphics 50 KATAKANA 64 International characters 12 Download characters 10 |
| Font configuration | 5 × 9 or 7 × 9 |

| Paper width | 3.25 inch (82.5 mm) | | | 3.0 inch (76 mm) | | | 2.25 inch (57.5 mm) | | |
|-------------------------|---------------------|---------|---------|------------------|---------|---------|---------------------|---------|---------|
| CPI | 14.9 | 12.5 | 8.3 | 14.9 | 12.5 | 8.3 | 14.9 | 12.5 | 8.3 |
| Number of columns | 40 | 33 | 22 | 40 | 33 | 22 | 28 | 23 | 15 |
| Dot space (H × V mm) | 0.340 | 0.340 | 0.510 | 0.340 | 0.340 | 0.510 | 0.340 | 0.340 | 0.510 |
| | × | × | × | × | × | × | × | × | × |
| | 0.353 | 0.353 | 0.353 | 0.353 | 0.353 | 0.353 | 0.353 | 0.353 | 0.353 |
| Column spacing (mm) | 1.70 | 2.04 | 3.06 | 1.70 | 2.04 | 3.06 | 1.70 | 2.04 | 3.06 |
| Character size (mm) | 1.32 | 1.66 | 2.34 | 1.32 | 1.66 | 2.34 | 1.32 | 1.66 | 2.34 |
| | × | × | × | × | × | × | × | × | × |
| | 2.42 | 2.42 | 2.42 | 2.42 | 2.42 | 2.42 | 2.42 | 2.42 | 2.42 |
| Total no. of dots | 200 | 198 | 132 | 200 | 198 | 132 | 140 | 138 | 90 |
| Print area (mm) | 67.7 | 67.0 | 66.8 | 67.7 | 67.0 | 66.8 | 47.3 | 46.6 | 45.4 |
| Left/Right margins | 7.4/7.4 | 7.4/8.1 | 7.4/8.3 | 4.2/4.2 | 4.2/4.8 | 4.2/5.0 | 5.1/5.1 | 5.1/5.8 | 5.1/7.0 |

| | |
|--------------------------------|---|
| Print speed: | Approx. 5.53 lines per sec. |
| Line spacing: | 1/6-inch (initial setting), 1/8-inch, 1/12-inch, n/72-inch, n/144-inch |
| Paper feed method: | Friction feed |
| Paper feed speed: | Approx. 3 inches/sec. |
| Paper specifications | |
| Paper type: | Ordinary bond and carbonless copy paper |
| Paper width: | 82.5 ±0.5 mm (3.25 inches) 76 ±0.5 mm (3.0 inches) 57.2 ±0.5 mm (2.25 inches) |
| Roll diameter: | 85 mm (3.35 inches) max. |
| Thickness | (single) 0.07 mm to 0.10 mm (copies) Original + 1 copy (Max. 0.14 mm) Original + 2 copies (Max. 0.2 mm) However, paper that can be cut with the auto cutter is one sheet of 0.06 – 0.085 mm thickness. |
| Internal diameter of roll: | 12 ±1 mm Note: The paper must not be glued to the core. |
| Ink ribbon specifications | |
| Ribbon type: | Cartridge cassette |
| Color: | Standard purple or optional black |
| Ribbon material: | Nylon (#40 denier) |
| Ribbon life: | Purple (standard) 6,000,000 characters Black (option) 1,600,000 characters |
| Interface: | |
| Serial interface: | RS-232C serial interface (standard) 20 mA current loop (option) RS-422A (option) |
| Parallel interface: | Centronics compatible |
| Data buffer: | Selectable between 1 K and 256 bytes |
| Peripheral unit drive circuit: | 2 circuits (24 V, max. 1 A with a 1 circuit compulsion switch) |
| Power Supply: | AC120 V ±10 % 60 Hz (for US) AC230 V –10 % ~ 240 V +10 % 50/60 Hz (for EU) AC220 V ±10 % 50/60 Hz (for Hong Kong, Korea) |

| | |
|-------------------------------------|--|
| AC power cable: | Approx. 155 cm long |
| Power consumption: | Max. 21 W Avg. 18 W (During continuous printing of ASCII characters) |
| Ambient temperature/humidity | |
| Operating temperature: | 0°C to +50°C |
| Operating humidity: | 10 % to 90 % RH (without condensation) |
| Storage temperature: | -20°C to +70°C |
| Storage humidity: | 5 % to 95 % RH (at 40°C) without condensation. |
| Mechanism reliability: | 5,000,000 lines MCBF (except head life and auto cutter) |
| Print head life: | One hundred million characters |
| Auto-cutter reliability: | 600,000 cut (MCBF) (SP347) |

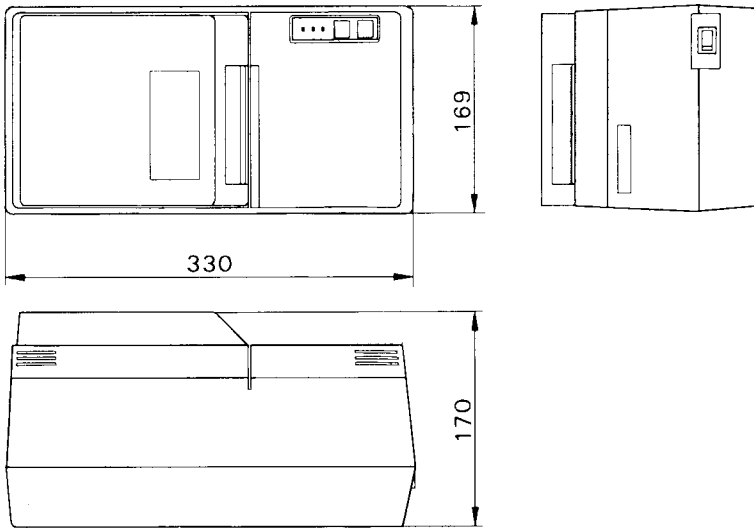

Overall dimensions (mm) (SP317)

169 W × 330 D × 170 H (mm)
 Approx. 3.5 kg

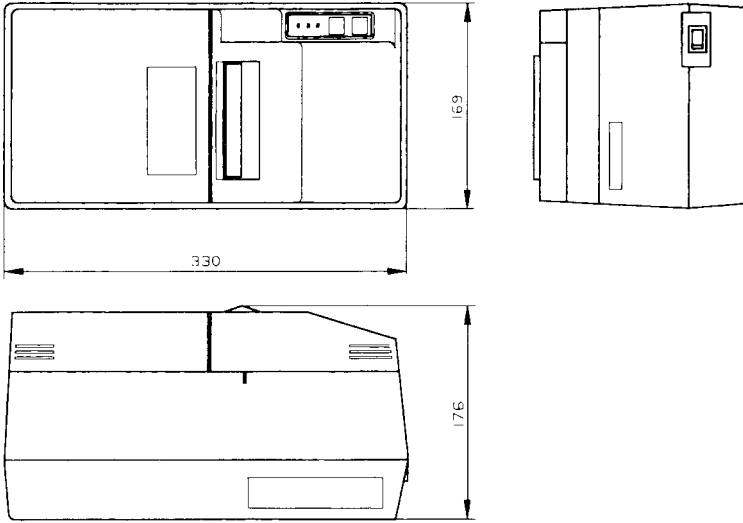

Overall dimensions (mm) (SP347)

169 W × 330 D × 176 H (mm)

Approx 3.8 kg

MEMO



**ELECTRONIC PRODUCTS DIVISION
STAR MICRONICS CO., LTD.**

536 Nanatsushinnya, Shimizu, Shizuoka,
424-0066 Japan
Tel: 0543-47-0112, Fax: 0543-48-5013

Please access the following URL
http://www.star-micronics.co.jp/service/sp_sup_e.htm
for the latest revision of the manual.

**OVERSEAS SUBSIDIARY COMPANIES
STAR MICRONICS AMERICA, INC.**

1150 King Georges Post Road, Edison,
NJ 08837-3729 U.S.A.
Tel: 732-623-5555, Fax: 732-623-5590

STAR MICRONICS U.K. LTD.

Star House, Peregrine Business Park, Gomm Road,
High Wycombe, Bucks, HP13 7DL, U.K.
Tel: 01494-471111, Fax: 01494-473333